



भारत सरकार Government of India
रेल मंत्रालय Ministry of Railways
(रेलवे बोर्ड Railway Board)



No. 2021/CEDO/SD/IRSOD2021

New Delhi, Dated 27.07.2022

As per list attached

Sub:- Indian Railways Schedule of Dimensions, 1676 Gauge, BG, Revised, 2022

1. Indian Railways Schedule of Dimensions, 1676 Gauge, BG, Revised- 2004 was published in year 2004.
2. Numbers of amendments have been issued to Indian Railways Schedule of Dimensions (BG) Revised, 2004. It was, therefore, considered necessary to revise Indian Railways Schedule of Dimensions (BG) (IRSOD)
3. Board (MOBD, MTRS, MI) has approved new Indian Railways Schedule of Dimensions (BG) Revised, 2022, incorporates the various provision as under:
 - i) Advance Correction Slips No. upto 32.
 - ii) New provisions for minimum wheel diameter of 840mm for goods vehicle along with minimum floor height/coupler & CBC height.
 - iii) Maximum diameter of 1250mm for locomotive.
 - iv) New chapter on **Track Machines**.
4. The IR-SOD Revised, 2022 has been uploaded on Railway Board's website. It may be accessed through the following path:
www.indianrailways.gov.in/railwayboard >> "About Indian Railways" >> "Railway Board Directorates" >> "Civil Engineering" >> "10. IRSOD" >> Document.

अजीत कुमार झा
27.7.22
(अजीत कुमार झा)

कार्यपालक निदेशक/सिविल इंजी.(जी)/रेलवे बोर्ड
[Phone: 030-44803: Rly: 011-23383379:MTNL]
e-mail address : edceg2022@gmail.com

Copy forwarded for information to:

1. The Chief Commissioner of Railway Safety, Office Compound of DRM/NER, Ashok Marg, Lucknow
2. The Commissioner of Railway Safety, All Circles

LIST FOR DISTRIBUTION (No. 2021/CEDO/SD/IRSOD2021, Dated 27.07.2022)

1. General Managers, All Indian Railways & Production Units
 2. General Manager (Con), N.F. Railway, Guwahati
 3. General Manager /CORE, Allahabad.
 4. Chief Administrative Officers (Con), All Indian Railways (Except N.F. Railway)
 5. Principal Chief Engineers, All Indian Railways
 6. PFAs, All Indian Railways
 7. THE Deputy Controller & Auditor General of India (Railways), Room No. 224, Rail Bhawan, New Delhi
- (A)
1. CAO, COFMOW, Tilak Bridge, New Delhi
 2. Principal CAO, Diesel Loco Modernization Works, Patiala (Punjab)
 3. CAO (Workshop Projects), Chamber Bhawan, Judge's Court Road, Anta Ghat, Patna-800001, Bihar
- (B)
1. Director General, RDSO, Manak Nagar, Lucknow
 2. Director General, NAIR, Vadodara
 3. Director, IRICEN, Pune - 411 001 (Maharashtra)
 4. Director, IRIEEN, PB No.-233, Nasik Road-422101 (Maharashtra)
 5. Director, IRISSET, Taa Naka Road, Lalla Guda, Secunderabad-500017
 6. Director, IRIMEE, Jamalpur Distt-Jamalpur, PIN-811214 (Bihar).
 7. Director, IRITM, Sarswati Residential Estate, IRITM Campus, Manak Nagar, Lucknow
- (C)
1. MD, CONCOR, Concor Bhawan, C-3, Mathura Road, Opp. Apollo Hospital, New Delhi- 110076.
 2. IRCON International Limited, C-4, District Centre, Saket, New Delhi- 110017
 3. MD, RITES Ltd., RITES Bhawan, Plot No.1, Sector-29, Gurgaon.
 4. CMD, RVNL, August Kranti Bhawan, Plot No.25, 1st Floor, Bhikaji Cama Place, New Delhi.
 5. MD, MRVC Ltd., Churchgate Station Bldg, Mumbai- 400020
 6. CMD, KONKAN Railway Corporation Ltd, Rail Bhawan, New Delhi-110001.
 7. MD, DFCCIL, 5th Floor, Pragati Maidan Metro Station Building Complex, New Delhi-110001
 8. MD, RLDA, Near Safdarjung Railway Station, Moti Bagh, Phase-I, New Delhi- 110021
 9. MD, CRIS, Chanakyapur, New Delhi.
 10. CMD, RailTel Corporation of India Ltd. Plot No. 143, Institutional Area, Sector-44, Gurgaon - 122003.
 11. CME, IROAF, 12th Floor, Core-1, Scope Minar, Distt. Centre, Laxmi Nagar, Delhi- 110092
 12. Managing Director, IRFC Limited, UG Floor, East Tower, NBCC Place, Bhasham Pitamah Marg, Lodhi Road, Pragati Vihar, New Delhi.
 13. CMD, IRCTC Ltd., B-148, 11th Floor, Statesman House, Barakhamba Road, New Delhi 110001
 14. CMD, Braithwaite & Co. limited, 5 Hide Road Kolkata 700043.

Copy to:

(A)

1. General Secretary, IRCA, DRM Office, New Delhi.
2. General Secretary, AIRF, Rail Bhawan, New Delhi
3. General Secretary, NFIR, Rail Bhawan, New Delhi
4. General Secretary, IRPOF, Rail Bhawan, New Delhi
5. General Secretary, FROA, Rail Bhawan, New Delhi
6. General Secretary, AIRPA, Rail Bhawan, New Delhi
7. General Secretary, AISC & STREA, Rail Bhawan, New Delhi
8. The Secretary, RBSS, Group (A) Offices Association, Rail Bhawan
9. The Secretary, RBSS, Group (B) Offices Association, Rail Bhawan
10. General Secretary, RBSSS Association, Rail Bhawan
11. The Secretary, RBMSA, Rail Bhawan
12. The Secretary, Railway, Group (D) Employees Association, Rail Bhawan

(B)

1. Concerned PSO for kind information of Chairman cum CEO, M/Infra, M/T&RS M/O&BD, M/Finance, Railway Board
2. Adv./MR, EDPG/MR, OSD/MR, OSR(Co-ord)/MR
3. Chief Vigilance Officers, All Indian Railways.
4. DG(RHS), DG(RPF), AM(CE), AM(Works), AM(B), AM(Elec.), AM(RS), AM(ME), AM/Tele, AM/C&IS, AM/Sig., AM(Plg.), PED(B&S), PED(Vigilance), PEDCE(P), EDCE(G), EDTK(M&MC), EDCE(B&S), EDF(X)-I, EDF(X)-II, ED(Works), EDW(Plg.), ED/Project(Mon.), ED(L&A), ED(PSU), EDVE, ED(Safety), ED(Sig. Dev.), ED(Tele), EDRS(G), EDRE, EDEE(G), EDFE, EDE(N), ED(Accounts), ED/T&MPP, EDME(Chg.), EDME(Frt.), ED/Plg., JS(conf), JS(P), JS(G), JS(D), Vigilance-III, Vig(Conf) of Railway Board.

FOREWORD TO IRSOD (BG) REVISED, 2022

Indian Railways Schedule of Dimensions, 1676 Gauge, BG was last Revised and published in year 2004. More than 32 advance correction slips have been issued since then. There have been many changes and therefore it is considered prudent to revise and update Indian Railways Schedule of Dimensions (BG) (IRSOD) incorporating all the changes. Schedule of dimensions for track machines have been added and efforts are made to avoid need for condonation by incorporating condonations already given by Railway Board.

It is expected that this IRSOD will be of immense use to all Railway officials in planning and designing structures and rolling stocks.

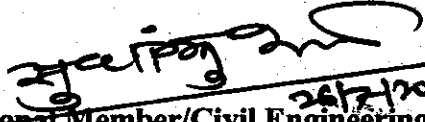
26/7/2022
Additional Member/Civil Engineering
Ministry of Railways, Railway Board
Rail Bhawan, New Delhi-110001

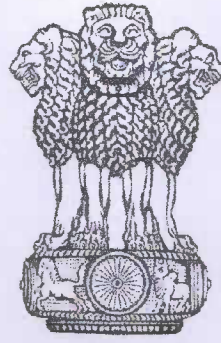

सत्यमेव जयते

INDIAN RAILWAYS
SCHEDULE OF DIMENSIONS
1676mm Gauge
(BG)

REVISED, 2022

(Corrected Upto ACS-02)

PREFACE

SCHEDULE OF DIMENSIONS-1676mm GAUGE

Schedule of Dimensions for Indian Railways, 1676mm Gauge

Dear Sir/Dear Sirs,

Railway Board issued a Schedule of Maximum, Minimum and Recommended Dimensions to be observed on all 1676mm gauge Railways in India through their circular letter No. 735-W. of 1922. In the Schedule, certain dimensions of the previous schedule of the year 1913 were modified with the object of permitting the use of modified rolling stocks.

2. The Schedule of Dimensions of 1922 contained two distinct sections, namely, a schedule of "Maximum and Minimum Dimensions" to enable the proposed modified vehicles to run with the same degree of safety as that of the existing rolling stock and a schedule of "Recommended Dimensions" intended to provide approximately the same clearances from fixed structures for the future vehicles.

3. In their circular letter No. 232-Tech., dated the 8th February, 1926, the Railway Board gave instructions that the Recommended Dimensions given in the 1922 Schedule were to be observed on important Railways in all new works and alterations to existing works. These orders were subsequently modified in letter No. 232-Tech. of the 26th April, 1926, which allowed a relaxation in the case of certain recommended dimensions, the adoption of which would involve heavy expenditure in remodeling works.

4. In 1929, it was found necessary to amend the Schedule of 1922 in order to incorporate certain improvements in the light of experience gained and also to provide the clearances required for electrification of lines. A few special dimensions were also required for "Standard C" railways as defined in the "Rules for preparation of Railway Projects 1926 - Chapter III, Standards of Construction".

5. The Schedule-I issued in 1929, therefore, embodied these amendments/additions and the deletion of procedures which were in the nature of mere practice rather than essential for safe working in the Schedule in 1922. These were, therefore, relegated to Schedule II, Recommended Dimensions.

6. Among the more important changes introduced in the 1929 Schedule, were an increase in the minimum height above rail level for overhead structures to 5410mm and increase to 2360mm in the horizontal distance to a fixed structure up to 3355mm above rail level, a reduction in this distance to 2135mm at 4420mm above rail level and a reduction also in the clearance to fixed structures from rail

level to 1065mm above rail level on bridges and in tunnels to allow a reduction in tunnel sections and an improvement in the disposition of bracing of bridge girders without sacrificing safety.

7. In 1936, however, the financial stringency on Railways, the general fall in Railway traffic generally and the increasing demand for light and fast units to compete with motor bus transport made the introduction of heavier engines and 3660mm wide stock on Railways improbable. In these circumstances, it was found desirable to alter the dimensions prescribed in Schedule I of the 1929 and to revert to the maximum and minimum dimensions in the 1922 Schedule in several important respects. Railway administrations were advised of these alterations through correction slip no. 14 of 1st December, 1936 to the 1929 Schedule. These alterations were not, however, intended to prevent the introduction of 3660mm stock at some future date, should this prove necessary. It had, therefore, been expressly laid down that the modifications made in Chapter I of Schedule I, were not to apply to Tunnels, Through and Semi-through Girder Bridges in respect of which the Standard Dimensions of 1929 would continue to apply.

8. The Schedule of dimensions, with metric and F.P.S dimensions which was forwarded in the year 1973 was based on the 1958 reprint of 1939 schedule, with the difference that the Chapter IV and IV SS of schedule- I, were combined and rearranged under two headings viz chapter IV (A) for carriage and wagon and chapter IV(C) for locomotive and the dimensions pertaining to 3050mm wide bogie stock were omitted from this version of 1973 schedule. Chapter IV-S relating to 3660mm wide stock were designated as chapter IV (B) for carriage and wagon. In converting F.P.S dimensions into metric, the dimensions of "wheel profile" were rounded off to the nearest 0.50mm, diameter of wheel and smaller dimensions less than 12 inches rounded off to the nearest mm, those of fixed structures and profile of rolling stock to the nearest 5mm and other larger dimensions to the nearest cm in metric unit depending on the accuracy required. Schedule II & III, showing Recommended Dimensions and Infringements of Schedule I respectively, which might be permitted on existing railways were retained and the appendix dealing with extra clearances required on curves were revised to show the clearances required for 3250mm wide and 21340mm long rolling stock. Also in the revised table, the maximum permissible speed and corresponding super-elevation were indicated and the required clearances based on these super elevations were given.

9. The dimensions prescribed in Schedule I were applicable to all new railways and to new works on existing railways, including, so far as practicable, alternations and renewals and departure from the above, needed prior sanction.

The clearances prescribed in item 13 of Chapter I 'Tunnel, through and semi-through girder bridges' was to be adopted for all structures including tunnels and through girder bridges of new

constructions and additions/alterations to the existing structures. If, however in case where 3660mm stock was not expected to be introduced or heavy expenditure involved, administrative reference to be made to the Board, individually in each case before execution of the work, for adopting less clearance.

10. The schedule of dimensions of 1973 version was based on the requirements of 25KV.A.C. traction and all future construction were to be carried out to these dimensions except in cases where it was considered that there was no chance of the line being subsequently converted to 25KV A.C. traction. A new chapter VA was added in respect of dimensions required for electric traction with 25KV A.C. 50 cycles.

11. The Indian Railways schedule of dimensions (BG) Revised, 2004 was a revised version of the Schedule of Dimensions of 1939 reprinted in 1973. The subject of review of B.G. Schedule of Dimensions 1939 reprinted in 1973 was discussed under item No. 821 of 64th Track Standards Committee meeting held in March 1990. Based upon the committee's recommendation on this item, Railway Board vide their letter no. 90/CE-II/TSC/1 dated 17.12.99 issued orders to Director General/RDSO to appoint a multi disciplinary committee for the revision of Schedule of Dimensions (1973 reprint). The Multidisciplinary committee consisted of the following directorates of RDSO:

- i) Track Design Directorate (Co-ordinating Directorate)
- ii) Bridges & Structures Directorate
- iii) Carriage Directorate
- iv) Motive Power Directorate
- v) Wagon Directorate
- vi) PS & EMU Directorate
- vii) Signal Directorate
- viii) TI Directorate

The Indian Railways schedule of dimensions (BG) Revised, 2004 consisted of only metric units. All dimensions in FPS units were deleted. The following modifications were done in Indian Railways schedule of dimensions (BG) Revised, 2004 over the structure of schedule of dimensions of 1973

- (a) Only two schedules - Schedule I & Schedule II, were provided in this revised Schedule of Dimensions. Schedule-I consisted of those items which were mandatory and were to be observed on all 1676mm Gauge Railways in India. It contained the items of Schedule-I & certain selected items of Schedule-II of 1973 version of Schedule of Dimensions.

- (b) Schedule-II consisted of items included in Schedule -III of 1973 version of Schedule of Dimensions.
- (c) For maximum moving dimensions, profile shown in diagram 1D (EDO/T-2202) was adopted which was based on the two profiles viz. EDO/T-1043 (for goods stock and locomotives) and sketch 72227 (for double Decker coach) which was approved by Railway Board vide their letter no. 72/WDO/SR/31 dated 21.2.1974 & 60/WDO/SR/19 dated 5.8.92 respectively.
- (d) The diagrams of Schedule of Dimensions reprint 1973 was suitably modified by replacing profile with profile (diagram 1D).
- (e) The appendix dealing with extra clearances required on curves was modified to suit maximum speed of 160 kmph with maximum super-elevation of 165mm and 100mm cant deficiency as per high speed Rajdhani and Shatabdi Routes, with other parameters kept as earlier. Additional appendix for extra clearances required on curves for maximum speed upto 200 kmph was also included in the Indian Railways Schedule of Dimensions (BG) Revised, 2004.
- (f) Various correction slips issued from time to time to Schedule of Dimensions of Reprint, 1973 were incorporated in the Indian Railways Schedule of Dimensions (BG) Revised, 2004.

12 Railway Board vide letter no. 2012/M(N)/951/14 dated 21.10.2021 and 07.11.2021 have directed that since a no. of amendments have been issued to Indian Railways Schedule of Dimensions (BG) Revised, 2004, there is a need to issue revised IRSOD. Accordingly, various correction slips issued from time to time to Indian Railways Schedule of Dimensions (BG) Revised, 2004 as listed in Annexure-II and new provisions for minimum wheel diameter of 840mm for goods vehicle along with minimum floor height/coupler & CBC height and maximum diameter of 1250mm for locomotive have been incorporated in this Indian Railway Schedule of Dimensions (BG), Revised – 2022.

Additional Member/Civil Engineering

Ministry of Railways, Railway Board

Rail Bhawan, New Delhi-110001

SCHEDULE – I
STANDARD DIMENSIONS

1676mm GAUGE (BG)

CHAPTER I – GENERAL

The DIMENSIONS given in this Schedule-I have been classified under two heads namely for ‘Existing works’ and for ‘New works’. Existing works means the works which were existing before issue of Indian Railway Schedule of Dimensions (BG), Revised-2004.

New works would include altogether new constructions, additions of new lines, new structures, gauge conversion and doubling. However, it does not include the works of alteration such as shifting of a Points and Crossings, extension of siding, extension of loop line, alteration in building etc.

The dimensions, except for existing works, are to be observed on all 1676 mm gauge on Indian Railways for execution of new works. Provided that infringement to any provision of IRSOD Chapter I, II, III, V, VA & VB of Schedule I can be condoned by the Commissioner, provided further that for infringement beyond the dimensions prescribed in Schedule II, if any, or wherever specific mentions appear in Schedule I, sanction for condonation shall be obtained from Railway Board through Commissioner/Chief Commissioner of Railway Safety.

[See Diagram Nos. 1A, 1A (Modified), 1B, 1C and 1D]

NOTE:

- (1) Items 8 and 10 are applicable only to structures outside station yards. All other items are of general applicability.
- (2) For running EMU and other 3660mm Stock on existing works, clearances prescribed in items 13(i) (a) and (ii) of Chapter I “Tunnels, Through and Semi Through, Girder Bridges” shall also be required for all structures governed by items 1(i), 7(i), 8(i) and 12 of this chapter and not only for tunnels, through and semi through girder bridges.

Spacing of Tracks:-

| | | |
|---|------------------------------------------------------|--------|
| 1 | Minimum distance center to center of straight tracks | |
| | (i) For existing works | 4265mm |
| | (ii) For new works/addition to existing works | 5300mm |

- Note:**
- (a) See Appendix for extra clearance required on curves.
 - (b) For spacing of tracks in tunnels, Road Over Bridges/Flyovers, through and semi through girder bridges, see item 13.

- (c) New/Additional works cover laying of new line and new running loops. Extension of existing line or replacement of points & crossings will not be treated as new work.
- (d) OHE mast and Signal post shall not preferably be provided in between tracks. However, under unavoidable circumstances, the clearances mentioned in para 1(ii) above shall be increased by equal to the width of such provisions/structures/foundation, as the case may be.
- (e) In case of tunnels, ROBs, flyovers, through & semi-through girder bridges, where center to center distance lesser than 5300mm between tracks has been provided, lesser center to center distance between tracks can be provided on approaches also up to adequate distance to facilitate gradual increase in center to center distance up to minimum 5300mm.
- (f) Further, in case lesser than 5300mm center to center distance between tracks has been provided in the existing station yard, lesser center to center distance between tracks can be provided on approaches towards block section also, up to adequate distance to facilitate gradual increase in centre to centre distance up to minimum 5300mm.

Curves:-

- | | | |
|---|--------------------------|-------------------|
| 2 | Minimum radius of curves | 175m (10 degrees) |
|---|--------------------------|-------------------|

Bridges:-

- 3 Bridges must conform to the requirements of chapter IV of the Railways opening for the Public carriage of Passengers, Rule 2000.

On existing bridges where there is nothing solid between sleepers to prevent a derailed wheel dropping, the clear distance between two consecutive sleepers shall not exceed 510mm. The clear distance between the joint sleepers shall not, however, exceed 200mm and that between the two consecutive sleepers 450mm in all new constructions and in existing bridges when regirdering or carrying out through sleeper renewal.

Bridge sleepers resting directly on longitudinal girders should not be less than 150mm deep exclusive of any notching which may be required to allow for cover plates, camber, etc and not less than 305mm greater in length than the distance outside to outside of girder flanges subject to a minimum of 2440mm. The minimum length of steel trough sleepers should be the distance outside to outside of girder flanges subject to a minimum of 2440mm

Rails:-

- | | | |
|---|----------------------------------------------|------|
| 4 | Minimum clearance of check rails for a curve | 44mm |
|---|----------------------------------------------|------|

Note: (a) This clearance must be increased by not less than half the amount of any difference between 1676mm and the gauge to which the curve is actually laid.
 (b) Check rail to be provided in curves where the radius is 218 m or less i.e. curvature is 8° or more. It may be required in the case of flatter curves also, if high speed is contemplated.

- | | | |
|---|----------------------------------------------------------|------|
| 5 | (i) Minimum clearance of check rail at a level crossing | 51mm |
| | (ii) Maximum clearance of check rail at a level crossing | 57mm |

| | | |
|---|---------------------------------------------------------|------|
| 6 | Minimum depth of space for wheel flange from rail level | 38mm |
|---|---------------------------------------------------------|------|

Buildings and structures:-

| | | |
|---|-------------------------------------------------------------------------------------------------------------|--------|
| 7 | Minimum horizontal distance from centre of track to any structure from rail level to 305mm above rail level | |
| | (i) For existing works | 1675mm |
| | (ii) For new works or alterations to existing works | 1905mm |

Note:

- (a) Any material stacked by the side of line is to be considered a structure in the sense in which the word is used here. These items also apply to projections of rock etc., from the side of cutting.
- (b) See appendix for extra clearance required on curves.

| | | |
|---|-------------------------------------------------------------------------------------|-----------------------------|
| 8 | Minimum horizontal distance from centre of track to any structure except a platform | |
| | (i) For existing works | |
| | From 305mm above rail level to 4420mm above rail level | 2135mm |
| | (ii) For new works or alterations to existing works | |
| | (a) From 305mm above rail level to 1065mm | 1905mm increasing to 2360mm |
| | (b) From 1065mm above rail level to 3355mm | 2360mm |
| | (c) From 3355mm above rail level to 4420mm | 2360mm decreasing to 2135mm |
| | (d) From 4420mm above rail level to 5870mm | 2135mm decreasing to 915mm |

Note:

- (a) Any material stacked by the side of line is to be considered a structure in the sense in which the word is used here. These items also apply to projections of rock etc., from the side of cutting.
- (b) See appendix for extra clearance required on curves.
- (c) Light structures such as ladders, thin posts etc. erected alongside the track at a distance of less than 2360mm from centre of adjacent track should be blanked off to a height of 300mm between 2060mm and 2360mm above rail level.

| | | |
|-------|-------------------------------------------------------------------------------------------------------------|--------|
| (iii) | (a) Below the rail level up to the formation level of the track on straight and curves up to radius of 875m | 2575mm |
| | (b) Below the rail level up to the formation level of the track on curves with radius less than 875m | 2725mm |

Note:

- (a) The required clearances as mentioned under item 8 (iii) (a) and (b) above will be applicable in case of new lines/doubling/electrification.
- (b) The various fixture which are attached to the track like traction bonds etc. and are required to be fitted with the rail can be provided and the clearance as mentioned in item 8 (iii) (a) & (b) above will not be applicable to these fixtures.

(c) The clearances as mentioned in item no. 8 (iii) (a) and (b) above will not be applicable in case of bridges, tunnels & ballastless track (including washable apron).

9 Minimum horizontal distance of any telegraph post measured from the centre of and at right angles to the nearest track.

(i) For existing works The height of the post plus
2135mm

(ii) For new works or alterations to existing works The height of the post plus
2360mm

Note: When the line is in cutting a telegraph post erected outside the cutting, must be at a distance from the edge of the cutting not less than the total height of the post.

10 Height of Road Over Bridges & Foot Over Bridges:

(a) Minimum height above rail level for a distance of 915mm on either side of the centre of track for overhead structures 4875mm

(b) Where D.C. electric traction is in use or is likely to be used, this dimension shall be 5410mm

(c) Where 25 KV A.C. traction is likely to be used, the minimum height above rail level for a distance of 1600mm on either side of the center of track shall be as under :

(i) Light Overhead structure, such as Foot Over Bridges 6250mm

(ii) Heavy Overhead Structure, such as Road Over Bridges and Flyovers 5870mm

Note:

(a) See appendix for 'extra clearance required on curves'.

(b) In case of restricted height of existing structures, a special study shall be made, as indicated in Appendix-A to Chapter V-A before 25 kV A.C. traction is introduced. Accordingly, only in such cases, the minimum height above rail level shall not be lower than 5070mm in case of Heavy Overhead Structure (such as Road Over & Flyover) and 5270mm in case of Light Overhead Structures (such as Foot Over Bridge) for a minimum contact wire height of 4800mm from above rail level. OHE arrangements shall be as per RDSO Drawings.

(c) In areas where 25 kV A.C. traction is used or likely to be used, if any turnout or crossover is located under a heavy overhead structure or within 40m from its nearest face, irrespective of the position of level crossing gate, the minimum height of such overhead structure shall be 6250mm*. In case the turnout is beyond 40m; but the level crossing gate is within 520m from the nearest face of the bridge, the height of such overhead structure shall be 6250mm*.

(d) The height mentioned against items 10(a), 10(b) & 10(c) above shall be measured from the higher or super elevated rail.

(e) On lines, existing or proposed to be electrified on 25kV A.C. system, necessary provision shall be made in overhead structure and overhead equipment, if necessary, by using longer traction overhead equipment masts to

permit an extra allowance of 275mm for raising of track in future to cater for modern track structure in the form of increased ballast cushion, larger sleeper thickness and deeper rail sections.

* In case of restricted height of existing heavy overhead structure, minimum height above rail level shall not be lower than 5270mm, adhering to the provisions of note (b) above.

(f) For Mumbai Suburban, the height of Foot Over Bridges mentioned under para 10(c)(i) above may be reduced to 5750mm subject to following conditions:

- (i) The minimum height of the contact wire shall be 4800 mm.
- (ii) A special study shall be conducted as indicated in appendix A of chapter V-A to ascertain the feasibility of the contact wire height as 4800mm.
- (iii) There shall be no crossover below FOB or within 40 m from the face of FOB.
- (iv) There shall be no level crossing within 520 m from face of FOB.
- (v) The maximum height of rolling stock shall be restricted to 4420 mm.
- (vi) The height shall be measured from the higher or super-elevated rail.

11. Clearance for Power line crossings including Telephone line crossings of Railway Tracks –

11(i) Clearances for Power line crossings in Non-Electrified & Electrified Territory:

| SL | Over head crossing voltage | Minimum clearances from Rail Level | | Minimum clearance between highest Traction Conductor and lowest Transmission line crossing conductor |
|-----|----------------------------|------------------------------------------------------------|------------------------------------------------------------|------------------------------------------------------------------------------------------------------|
| | | Existing power line crossing for Non-Electrified Territory | New power line crossing or crossing planned for alteration | |
| (1) | (2) | (3) | (4) | (5) |
| 1. | Upto and including 11kV | Normally by underground cable | | |
| 2. | Above 11kV & upto 33kV | 10860 mm | 14660 mm | 2440 mm |
| 3. | Above 33kV & upto 66kV | 11160 mm | 14960 mm | 2440 mm |
| 4. | Above 66kV & upto 132kV | 11760 mm | 15560 mm | 3050 mm |
| 5. | Above 132kV & upto 220kV | 12660 mm | 16460 mm | 4580 mm |
| 6. | Above 220kV & upto 400kV | 14460 mm | 18260 mm | 5490 mm |
| 7. | Above 400kV & upto 500kV | 15360 mm | 19160 mm | 7940 mm |
| 8. | Above 500kV & upto 800kV | 18060 mm | 21860 mm | 7940 mm |

Note :

- (i) All height/clearances are in mm and under maximum sag conditions.
- (ii) If the crossing is provided with a guarding, a minimum clearance of 2000mm shall be maintained between bottom of guard wire and highest traction conductor.
- (iii) Power line crossing in yards and stations area shall be avoided.

(iv) For electrification works of existing track or construction of new track/gauge conversion with electrification, existing power line crossings can continue, if dimensions are as per column (5) above, even if dimensions of column (3) are not satisfied i.e., for electrification works column (3) is not applicable.

11(ii) Minimum clearance between any conductor not adequately insulated and any railway structure under most adverse conditions.

| SL | Voltage | Minimum Clearance |
|-----|--------------------------------------------|-------------------|
| (1) | (2) | (3) |
| (a) | Upto and including 650 volts | 2500mm |
| (b) | Above 650 volts and upto & including 33 kV | 3700mm |
| (c) | Above 33 kV and upto & including 66 kV | 4000mm |
| (d) | Above 66 kV and upto & including 132 kV | 4600mm |
| (e) | Above 132 kV and upto & including 165 kV | 4900mm |
| (f) | Above 165 kV and upto & including 220 kV | 5500mm |
| (g) | Above 220 kV and upto & including 400 kV | 7300mm |
| (h) | Above 400 kV and upto & including 500 kV | 8200mm |
| (i) | Above 500 kV and upto & including 800 kV | 10900mm |

11(iii) Minimum height above rail level for telegraph, telephone and other such low tension wires crossing a railway 6100mm

11(iv) Minimum Horizontal Distance of Structures:

The minimum horizontal distance measured at right- angle to, and from the centre of nearest track to any part of the structure above ground level, carrying electrical conductor crossing a railway line shall be:

- (i) For new structure : (H+6) m
- (ii) For existing rigid well founded post/structures : 3m, or 1.5m away from the toe of embankment/top of cutting, whichever is more

Where, 'H' is the height of post/structure from nearest ground level

Note :

1. Rigid well founded post/structure: Any post/structure which is so constructed or guyed as to remain in a vertical position, or failing this to continue to provide the minimum horizontal clearances of 2.135m from the centre of nearest track, with one or all of the conductors broken or with its conductors attached, when subjected to maximum wind pressure, shall be considered to be a "rigid well founded post/structure".

The existing rigid well founded post/structures, presently at a distance equal to or more than (ii) as given above, but less than (H+2.135)m, shall be inspected by railway's nominated electrical official once in a year jointly with the owner of the post/structure and certify the safety of the structure, keeping appropriate records of inspections.

2. If the existing post/structure carrying electrical conductors crossing a railway line, is not rigid and well founded then the minimum horizontal distance, measured at right angles from the centre of nearest track, shall be equal to height of post/structure above ground level plus 2.135m.

Interlocking and signal gear:-

- 12 Maximum height above rail level of any part of interlocking or signal gear for a width of 1600mm or 1830mm in the case of tunnels, through and semi-through girder bridges on either side of centre of track subject to the restriction embodied in the note (a) below. 64mm

Note: -

- a) For a distance of 229 mm outside and 140mm inside the gauge faces of the rail, no gear or track fittings must project above rail level except such parts as are required to be actuated by the wheels or wing rails and point rails of special crossings leading to snag dead ends or elevated check rails of crossing or check rails/check flats of diamond crossings.
- b) Signal wires or supports for signal wires may be allowed at not less than 1600 mm or 1830mm in the case of tunnels or through or semi-through girder bridges [see note at item 32 of chapter IV(A)] on either side of the centre of track provided that they are not more than 203mm above rail level.
- c) Metal covers with ramps on both sides must be provided over all interlocking gear projecting above rail level between the rails of a track to prevent hanging couplings from damaging the gear.

Tunnels, Through Girder Bridges and Semi-Through Girder Bridges:

[(See diagram No.1A; 1-A (Modified))]

- 13 (i) Minimum distance at centre to centre of track
- (a) For existing lines 4495mm
 - (b) For new works and alterations to existing works 4725mm
- (ii) Minimum horizontal distance from centre of track to any structure shall be as follows:

| <u>Height above rail level</u> | <u>Horizontal distance from centre of track</u> |
|--------------------------------|-------------------------------------------------|
| (a) From 0.0mm to 305mm | 1905mm |
| (b) From 305mm to 1065mm | 1905mm increasing to 2360mm |
| (c) From 1065mm to 3355mm | 2360mm |
| (d) From 3355mm to 4420mm | 2360mm decreasing to 2135mm |
| (e) From 4420mm to 5870mm | 2135mm decreasing to 915mm |

Note:

- (i) Where electric traction is not likely to be used, over-head bracing of bridges may be 5030mm above rail level for a distance of 1370mm on either side of the centre of track.
- (ii) In case of existing structures, a special clearance study shall be made which will be accepted by Electrical Inspector of the Railways, as indicated in Appendix-A to chapter V-A before electric traction is introduced.
- (iii) See Appendix for extra clearances required on curves.

- (iv) Where D.C. traction is in use, Para 13(ii) (e) above shall be as under:
From 4420mm to 5410mm : 2135mm decreasing to 915mm
- (v) Tunnels, through girder and semi through girder bridges outside station yards should be treated as heavy overhead structures such as ROB for electrification works and the same dimensions as mentioned in note (c) at para 10 above shall be applicable and OHE arrangement shall be as per RDSO Drawings.

Safety Refuges:

| | | |
|----|--------------------------------------------------|-------------------------|
| 14 | Maximum distance apart of refuges in tunnels | 100m |
| 15 | Maximum distance apart of trolley refuges: | |
| | (i) On bridges with main spans of less than 100m | 100m |
| | (ii) On bridges with main spans of 100m or more | A refuge over each pier |

Formation width:

| | | |
|----|------------------------------------------------------|---------|
| 16 | Formation width for single line straight track | |
| | (i) For existing works | |
| | (a) Minimum width in embankment | 6850mm |
| | (b) Minimum width in cutting (excluding side drains) | 6250mm |
| | (ii) For new works/alteration to existing works | |
| | (a) Minimum width in embankment | 7850mm |
| | (b) Minimum width in cutting (excluding side drains) | 7850mm |
| 17 | Formation width for double line straight track | |
| | (i) For existing works | |
| | (a) Minimum width in embankment | 12150mm |
| | (b) Minimum width in cutting (excluding side drains) | 11550mm |
| | (ii) For new works/alteration to existing works | |
| | (a) Minimum width in embankment | 13160mm |
| | (b) Minimum width in cutting (excluding side drains) | 13160mm |

Note:

- (a) The minimum formation width is based on:
 - (i) Ballast section having 1.5:1 side slope.
 - (ii) Cross slope on top of formation of 1 in 30
 - (iii) Track center in case of double line section is 5300 mm

18 Formation width on curves:

- (a) Increase due to extra ballast on outside of curves:

On curves, the actual width to be provided should take into account 150mm extra widening of ballast shoulder (500mm in place of 350mm) required on the outer side of curves. Thus, additions in the width on this account will be 150mm for single line and 300mm for double line.

- (b) Increase on double line due to effect of super-elevation:

Due to requirement of extra clearances on double line on curves, increase in track centre with corresponding increase in formation width would be necessary to take into account the effect of super-elevation.

Increase in formation width on curves will be decided after taking into account the increase mentioned in (a) & (b) above.

19. **Gauge on straight and curves:** The gauge shall be as follows:

- | | | |
|------|--------------------------------------------------|---------------------------------------|
| (i) | Straight including curves of 350m radius or more | -5mm to +3mm i.e. 1671mm to 1679mm |
| (ii) | For curves of radius less than 350m | up to +10mm i.e.1686mm |

CHAPTER II--- STATION YARDS

(See Diagram No. 2)

Note:

- (1) The expression "in station" as mentioned in Diagram No. 2 is to be interpreted in accordance with the definition of "station limits" given in chapter I, part I, of the General Rules for open lines, viz "station limits" means the portion of a railway which is under the control of a station master and is situated between the outermost signals of the station.
- (2) For running EMU and other 3660 mm stock, clearances prescribed in item 13(i)(a) and (ii) of chapter I "Tunnel, through and semi-through girder bridges" shall also be required for all structures governed by items 1(i) and 11(A) of this chapter and not only for tunnels and through and semi through girder bridges. However, a platform shelter may infringe item 13(ii) (e) of chapter I and edge of the platform shelter may be kept at a minimum horizontal distance of 1600 mm from centre line of track and at a minimum height of 4610mm above rail level.

Spacing of tracks:-

| | | |
|------|------------------------------------------------------|--------|
| 1 | Minimum distance centre to centre on straight tracks | |
| (i) | For existing works | 4265mm |
| (ii) | For new works/ addition to existing works | 5300mm |

Note:

- a) See Appendix for 'extra clearance required on curves'.
- b) In case new OHE masts/Signal posts are required to be provided in between tracks under unavoidable circumstances, the clearance maintained in 1(ii) above shall be increased by equal to the width of such provisions/structures/foundations, as the case may be.
- c) For "New Works/additions to existing works such as conversion of existing loop lines into main line, laying of new loop lines and/or shifting of existing lines etc" in the existing yard, if the stipulation mentioned in 1(ii) and Note (b) above are not likely to be achieved due to existing field constraints, then minimum horizontal distance from center of track to any structure, as mentioned in Note (c) of para 11(B) of Chapter-II, IRSOD-2022 shall be ensured.
- d) In completely new yard or portion of existing yard, where "New Work" is being done independent of the existing yard, stipulation under 1(ii) above shall be ensured.
- e) In case of tunnels, ROBs, flyovers, through & semi-through girder bridges, where centre to centre distance lesser than 5300mm has been provided, lesser centre to centre distance can be provided on approaches also up to adequate distance to facilitate gradual increase in centre to centre distance up to 5300mm.

2 Maximum (Steepest) gradient in station yards –

Maximum (Steepest) gradient in station yards, unless special safety devices are adopted and/or special rules enforced to prevent accidents in accordance with approved special instructions.

| | | | |
|------|-----------------------------------------------|---|--------------------|
| (i) | For New Works & Alteration to Existing Works- | | |
| (a) | Recommended | : | 1 in 1200 (0.083%) |
| (b) | Maximum (Steepest) | : | 1 in 400 (0.25%) |
| (ii) | For Existing works | : | 1 in 400 (0.25%) |

Note:

- f) Recommended dimension is generally the good practice, the adoption of which will lead to desirable uniformity on Indian Railways; but it is not to be treated as standards, a departure from which requires sanction.
- g) In case, it is not possible to provide recommended gradient of 1 in 1200 (0.083%) in yard even after making efforts to provide grades as flat as possible, reasons for deviation from recommended gradient and upto the specified maximum (steepest) gradient of 1 in 400 (0.25%) shall be recorded on the ESP. However, for new yards in new line projects adoption of yard gradient steeper than 1:1200 will require approval of General Manager before finalization of ESP.
- h) No station yard shall be constructed nor shall any siding join a passenger line on a grade steeper than 1 in 100 (1.0%), except where it is unavoidable and then also only with the previous sanction of Railway board, obtained through the Commissioner of Railway Safety, when adequate arrangements are made to prevent accident.
- i) The powers of condonation for gradient steeper than the specified standard maximum gradient of 1 in 400 (0.25%) shall be as under:

(i) Existing Yard:
Steeper than 1 in 400(0.25%) and upto 1 in 100 (1.0%) : ~~Commissioner of Railway Safety~~
General Manager through Principal Chief Safety Officer (PCSO)
(ACS No.02 dated 27.02.2023)

Steeper than 1 in 100 (1.0%) : Railway Board through Chief Commissioner of Railway Safety

(ii) For New Yard in New Line Projects:
Steeper than 1 in 400 (0.25%) and 1 in 260 (0.38%) : Commissioner of Railway Safety upto

Steeper than 1 in 260 (0.38%) : Railway Board through Chief Commissioner of Railway Safety

j) For above purpose, "Station yard" means:

i) On single line to a distance of 50 m beyond Stock Rail joint of outermost points at either end of the station. ii) On double line where 2 Aspect Signaling is provided:

For each line, from Home signal to a distance of 50m beyond Stock Rail joint of outermost facing point or Fouling Mark of outermost trailing point or up to Last Stop Signal where there is no point. iii) On double or multiple lines where Multiple Aspect Signaling is provided, for each line:

At either end, to a distance of 50 m beyond Stock Rail Joint of outermost facing point or to a distance of 50m beyond Fouling Mark of outermost trailing point, as the case may be; or where there are no points on that line, from Block Section Limit Board to Last Stop Signal.

k) There must be no change of grades within 30m of any points or crossings.

- (g) In case of “New Lines” projects, the above provisions shall also apply to Flag station, Halt station, or class ‘C’ station (where there is no station section as defined in IR General Rules, 1976). This is to keep provision for conversion of Flag, Halt, or class ‘C’ station into class ‘A’ or ‘B’ station in future.
- (h) For other than ‘New Lines’ projects, the above provisions shall not be applicable for Flag station, Halt station, or class ‘C’ station.

Platforms:

| | | | |
|---|-----|-------------------------------------------------------------------------------|--------|
| 3 | (i) | Horizontal distance from centre of track to face of passenger platform coping | |
| | | Maximum | 1680mm |
| | | Minimum | 1670mm |

Note :

- (i) The coping of passenger platform must be so constructed that when necessary, to allow for introduction of wider stock, it can be easily and expeditiously set back to 1905 mm. from centre of track (see diagram no. 2)
- (ii) Horizontal distance from centre of track to face of goods platform coping

| | |
|---------|--------|
| Maximum | 1680mm |
| Minimum | 1670mm |
- iii) Horizontal distance from centre of track to face of any platform wall.

| | |
|---------|---------|
| Maximum | 1905 mm |
| Minimum | 1675 mm |

Note:

- (a) New platform walls should be built to maximum dimensions and the coping corbelled out to 1675mm unless provision is made to allow for the introduction of wider rolling stock either by slewing the platform track out by 230 mm or by moving the platform wall 230 mm farther from the track.
- (b) See Appendix for extra clearance required on curves.

| | | |
|---|----------------------------------------------------------------------------------------------|--------------------------------|
| 4 | Height above rail level for high passenger platforms | 840mm maximum 760mm minimum |
| 5 | Maximum Height above rail level for medium level passenger platform | 455mm |
| 6 | Maximum height above rail level for goods platforms (except horse and end loading platforms) | 1065mm |

Note: For items 4, 5 and 6

- (a) Platforms may be flush with rail level.
- (b) The ends of all platforms (except end loading platforms) must be ramped to a slope of 1 in 6 for a width of not less than 1 m from the face of the platform wall, the rest can either be ramped to the same slope or fenced.
- (c) The height of platforms serving canted track should be measured vertically from the face to a plane passing through the top of both the rails.

- (d) End loading platforms and platforms on sidings used exclusively for horse loading may be raised to a height of 1295mm above rail level.
- (e) Signal wires or supports for signal wires may be allowed underneath the platform coping.
- (f) The length of a passenger platform should be not less than the length of the longest passenger train excluding the engine, booked to stop at the platform.
- (g) No passenger platform in case of new line, would be constructed on a curve having radius less than 875m.
- (h) In case of construction of a new platform on the existing line addition/alteration to existing platforms or in gauge conversion/doubling works, where either the new platform(s) are to be constructed or the old being dismantled and reconstructed, efforts should be made to ease out the existing curves having radii less than 875 m. However, for these works, having platform located/to be located on curves with radii less than 875 m, no condonation of CRS/Board would be necessary.
- (i) For Item 4: the height for Mumbai suburban passenger platform and Pune suburban passenger platform may be in range of 840mm-900mm for reducing gap between bottom of sole bar of EMU coach & platform floor and shall be applicable for operation of EMU stocks having height of bottom of sole bar above rail level not less than 1039mm above rail level in fully loaded condition. The height of platform more than 840mm shall be permitted by General Manager, after ensuring maintenance condition of track and maintenance condition of rolling stock as under:
 - a. Improvement in maintenance practices and monitoring condition of spring during trip inspection of EMU rakes.
 - b. Improvement in track maintenance on platform lines to the standards specified in Para 522 of IRPWM - 2020.
 - c. Improved monitoring and corrective action to control sinkage of vertical level of track.
 - d. In case, a new design EMU stock, different from the existing stock is to be introduced on suburban section, running trial over increased height suburban platforms shall be required before clearing the stock for passenger operation.

Buildings and structures:

- 7 (a) Minimum horizontal distance of any building/structure on a passenger platform from centre line of track:
- (i) From platform level to 305mm above platform level 5180mm increasing uniformly to 5330mm
 - (ii) From 305mm above platform level to 3430mm above rail level 5330mm
 - (iii) From 3430mm above rail level to
 - (a) 4115mm above rail level in case of existing works 5330mm decreasing uniformly to 3810mm
 - (b) 4610mm above rail level in case of new works or alterations to existing works 5330mm decreasing uniformly to 3810mm

Note:

- (1) For the return end of platform fencing these dimensions may be reduced to 2740mm.
- (2) Isolated structures are covered in Item 8 below.
- (3) In Mumbai suburban area, when it is not possible to provide platform width to meet provisions at 7(a) (i), 7(a) (ii) and 7(a) (iii) above, the dimensions at 7(a) (i), 7(a) (ii) and 7(a) (iii) can be reduced by Commissioner of Railway Safety for construction of new foot over bridge on the platform, on case to case basis subject to stipulations (a), (b), (c) & (d) below, as under:

- | | |
|--------------------------------------------------------------|----------------------------------------|
| (i) From platform level to 3430mm above rail level | 4115 mm |
| (ii) From 3430mm above rail level to 4610mm above rail level | 4115 mm decreasing uniformly to 3810mm |

- (a) The supporting column of FOB deck and landing on platform shall be designed in such a way that there is no lateral bracing between two columns up to a height of 2400 mm from platform level to allow free movement of passengers.
- (b) The FOB structure as well as platform surface in the 'entire zone covering the members of FOB having horizontal clearance less than 5330 mm from centerline of track from PF level to 2400 mm above PF level' shall be painted with yellow and red retro reflective paint strips to alert the alighting passengers. No temporary or permanent structure, no stabling of hand trolley shall be permitted in this zone. This area shall be well illuminated during night time.
- (c) No Slewing of track towards adjoining platform shall be permitted in the FOB zone.
- (d) In any case, FOB landing width should not be more than 50% of Platform width.

7 (b) Minimum horizontal distance of any building or longitudinal boundary fence from the centre line of track of passenger platform which is not an island platform (for new works or alterations to existing works):

- | | |
|------------------|---------|
| (i) Minimum | 6830mm |
| (ii) Recommended | 12130mm |

Note:

- (a) Item 7(b) (ii) allows for setting back the platform to make room for an additional track in future, without infringing item 7(b) (i).
- (b) Item 7(b) should also apply to buildings and isolated structures not readily removable, erected on ground over which it is anticipated that a platform may be extended in future.
- (c) Item 7(b) (i) may be reduced to 5330mm in case of foot over bridge at any station and/or provision of longitudinal boundary fence at 'D', 'E' and 'F' category stations; subject to stipulation that if any other pucca construction of building/structure is done in future, provisions of Item 7(a) & 7(b) shall be followed.
- (d) In Mumbai suburban section, for construction of new foot over bridge on the platform, provision of item 7(a) shall be applicable.

8 Minimum horizontal distance from centre line of track to a pillar, column, lamp or similar isolated structure on a passenger platform or any building on a goods platform.

- | | | |
|-------|-------------------------------------------------------------------------------|---------------------------------------|
| (i) | From platform level to 305mm above platform level | 4570mm increasing uniformly to 4720mm |
| (ii) | From 305mm above platform level to 3705mm above rail level | 4720mm |
| (iii) | From 3705mm above rail level to | |
| (a) | 4115mm above rail level in case of existing works | 4720mm decreasing uniformly to 3810mm |
| (b) | 4610mm above rail level in case of new works or alterations to existing works | 4720mm decreasing uniformly to 3810mm |

8A. Minimum horizontal distance from centre line of track to a pillar, column, lamp or similar isolated structure on goods platforms:

- | | | |
|-------|------------------------------------------------------------------------------------------------------------------|---------------------------------------|
| (i) | From platform level to 305mm above platform level | 3960mm increasing uniformly to 4110mm |
| (ii) | From 305mm above platform level to | |
| (a) | 3980mm above rail level in case of existing works | 4110mm |
| (b) | 4310mm above rail level in case of new works or alterations to existing works | 4110mm |
| (iii) | (a) From 3980mm above rail level to 4115mm above rail level in case of existing works | 4110mm decreasing uniformly to 3810mm |
| | (b) From 4310mm above rail level to 4610mm above rail level in case of new works or alteration to existing works | 4110mm decreasing uniformly to 3810mm |

Note:

A pillar or column (vide items 8 & 8A) which covers more than 3716 sq.cm in plan, must be classed as "building" and not as "isolated structure".

9 Minimum height above rail level for a width of 1600mm on either side of the centre of track, of tie rods or any continuous covering in a passenger station 6250mm

Note:

- | | | |
|-----|--------------------------------------------------------------------------------------------------------------------------------------------------------------------------------------------------------------|--------|
| (1) | On lines other than main lines where 25 kV A.C. electric traction is not likely to be used, the dimensions given above may be modified as under: For a width of 1370mm on either side of centre of track: | 6100mm |
| (2) | On existing primary lines, not likely to be electrified, dimension as in Note (1) may be allowed to Continue | |

- (3) Item 9 does not apply to over head piping parallel to the track.
- (4) A low roof that infringes item 9 is permissible in the case of goods or transshipment shed on a siding, provided it does not infringe the outline of the figures for the minimum fixed structure out of stations (see diagram 1B).
- (5) Extra vertical clearance of 275mm under over head structures and overhead equipment in electrified section be provided to allow for any raising of track to permit modern track structure to be introduced.

Note:

On lines proposed to be electrified on 25 kV A.C system, necessary provision should be made in overline structures and overhead equipment if necessary by using longer traction overhead equipment masts to permit possible raising of the track by 275mm in future to cater for increased ballast cushion, larger sleeper thickness and deeper rail sections.

10 Height of Over Head Structures –

Minimum height above rail level for a width of 1600mm on either side of 6250mm
centre of track, of a foot over bridge or a signal gantry in a passenger station

Note:

- (a) Where D.C. traction is in use or likely to be used, this minimum height shall be 5410mm.
- (b) On secondary lines, where electric traction is not likely to be introduced, this minimum height shall be 4875mm. This also applies to overhead piping arrangements parallel to track wherever provided, which shall necessarily be changed over to the ground hydrants, when the section is electrified.
- (c) However, for existing overhead structure, dimensions given in note (c) of para 10 of Chapter-I, Schedule -1: General shall be applicable.
- (d) Tunnel, through girder bridge and semi-through girder bridge in station yards shall be treated as heavy over head structures, such as ROB for electrification works and the same dimensions as mentioned in note (c) of para 10 of schedule 1, chapter -1 : General shall be applicable.
- (e) For Mumbai Suburban, the height of Foot Over Bridges mentioned above may be reduced to 5750mm subject to following conditions:
 - (i) The minimum height of the contact wire shall be 4800 mm.
 - (ii) A special study shall be conducted as indicated in appendix A of chapter V-A to ascertain the feasibility of the contact wire height as 4800mm.
 - (iii) There shall be no crossover below FOB or within 40 m from the face of FOB.
 - (iv) There shall be no level crossing within 520 m from face of FOB.
 - (v) The maximum height of rolling stock shall be restricted to 4420 mm.

(vi) The height shall be measured from the higher or super-elevated rail.

11 Minimum Horizontal Distance from centre of track to any structure:

(A) For existing works:

| | |
|-------------------------------------------------------------------------------------------------------------|-----------------------------|
| (i) From rail level to 305mm above rail level | 1675mm |
| (ii) From 305mm to 3355mm above rail level | 2135mm |
| (iii) From 3355mm to 4115mm above rail level | 2135mm decreasing to 1980mm |
| (iv) From 4115mm to 6250mm above rail level | 1600mm |
| (v) Below the rail level and up to formation level of the track on straight and curves up to radius of 875m | 2575mm |
| (vi) Below the rail level and upto the formation level of the track on curves with radius less than 875m | 2725mm |

Note:

- a) See appendix for 'extra clearances required on curves'.
- b) On lines other than main lines or existing main lines, where electric traction is not likely to be introduced, the horizontal distance of 1370mm for height from 4115mm to 6100mm above rail level may be allowed to continue.
- c) The various fixtures, which are attached to the track like lock bar, point machine, traction bonds, point and signal rodding etc. and are required to be fitted with the rail, can be provided and the clearance, as mentioned in item (v) and (vi) above will not be applicable to these items.
- d) In case of electrification works in existing yards, no foundation/mast/signal post/any other structure shall be provided between two tracks. In case it is inescapable, the minimum distance of edge of foundation/mast/signal post/any other structure at and above formation level upto rail level from centre of track, shall be 2360mm on straight track & on curve having radius 875m & more and 2510mm in case of curve having radius less than 875m.
- e) Items (v) and (vi) above shall not be applicable in case of bridges, tunnels and ballastless track (including washable apron).

(B) For New Works or Alteration to Existing works:

| | |
|-----------------------------------------------|-----------------------------|
| (i) From rail level to 305mm above rail level | 1905mm |
| (ii) From 305mm to 1065mm above rail level | 1905mm increasing to 2360mm |
| (iii) From 1065mm to 3735mm above rail level | 2360mm |
| (iv) From 3735mm to 4420mm above rail level | 2360mm decreasing to 2135mm |
| (v) From 4420mm to 4610mm above rail level | 2135mm decreasing to 1980mm |
| (vi) From 4610mm to 6250mm above rail level | 1600mm |

- | | | |
|--------|-------------------------------------------------------------------------------------------------------|--------|
| (vii) | Below the rail level and upto formation level of the track on straight and curves upto radius of 875m | 2575mm |
| (viii) | Below the rail level and upto the formation level of the track on curves with radius less than 875m. | 2725mm |

Note:

- (a) See Appendix for 'extra clearances required on curves'.
- (b) Items (vii) & (viii) above shall not be applicable in case of bridges, tunnels, ballastless track (including washable apron).
- (c) For addition/alteration to works in existing yard the minimum horizontal distance shall be maintained as 2360mm on straight track and on curve having radius 875m & more, and 2510mm in case of curve having radius less than 875m, if it is difficult to provide prescribed clearances as mentioned in items (vii) and (viii) above due to existing field constraints.
- (d) The various fixtures which are attached to the track like traction bonds etc. and are required to be fitted with the rail can be provided and the clearance as mentioned in item (vii) and (viii) above will not be applicable to these fixtures.

Points and crossings:

| | | |
|----|-----------------------------------------------------------|------|
| 12 | Maximum clearance of check rail opposite nose of crossing | 48mm |
|----|-----------------------------------------------------------|------|

Note: In case of turnouts laid with 1673mm gauge, the clearance shall be 45mm instead of 48mm.

| | | |
|----|-----------------------------------------------------------|------|
| 13 | Minimum clearance of check rail opposite nose of crossing | 44mm |
|----|-----------------------------------------------------------|------|

Note: In case of turnouts laid with 1673mm gauge, the clearance shall be 41mm instead of 44mm

| | | |
|----|----------------------------------------------------|------|
| 14 | Maximum clearance of wing rail at nose of crossing | 48mm |
|----|----------------------------------------------------|------|

Note: In case of turnouts laid with 1673mm gauge, the clearance shall be 45mm instead of 48mm

| | | |
|----|----------------------------------------------------|------|
| 15 | Minimum clearance of wing rail at nose of crossing | 44mm |
|----|----------------------------------------------------|------|

Note: In case of turnouts laid with 1673mm gauge, the clearance shall be 41mm instead of 44mm.

| | | |
|----|-------------------------------------------------------------|-------|
| 16 | Minimum clearance between toe of open switch and stock rail | |
| | (i) For existing works | 95mm |
| | (ii) For new works or alterations to existing works | 115mm |

Note: The clearance can be increased upto 160mm in curved switches in order to obtain adequate clearance between gauge face of stock rail and back face of tongue rail.

| | | |
|----|--------------------------------------------------------------------------|------------------|
| 17 | Minimum radius of curvature for slip points, turnouts or crossover roads | 218 m (8 degree) |
|----|--------------------------------------------------------------------------|------------------|

Note: In special cases mentioned below this may be reduced to not less than the minimum of

- i) 213m radius in case of 1 in 8.5 BG turnouts with 6.4m overriding switch, and
- ii) 175m radius in case of 1 in 8.5 scissors crossing to allow for sufficient straight over the diamond crossing between crossovers.

18 Minimum angle of crossing (ordinary) 1 in 16

Note: Crossings as flat as 1 in 20 will usually be sanctioned if recommended by the Commissioner of Railway Safety.

19 Diamond crossings not to be flatter than 1 in 8.5

Note: Diamond crossings as flat as 1 in 10 will usually be sanctioned if recommended by the Commissioner of Railway Safety.

20 Minimum length of tongue rail 3660mm

21 Minimum length of train protection, point locking or fouling treadle bar 12800mm

Note: There must be no change of super elevation (of outer over inner rail) between points 18m outside toe of switch rail and nose of crossing respectively, except in the case of special crossings leading to snag dead-ends or under circumstances as provided for in item– 22.

22 Superelevation and speed in stations on curves with turnouts of contrary and similar flexure:

Main line: Subject to the permissible run through speed, based on the standard of interlocking, the equilibrium superelevation, calculated for the speed of the fastest train, may be reduced by a maximum amount of 75mm without reducing the speed on the mainline.

Turnouts:

i) Curves of contrary flexure:-

The equilibrium superelevation in millimeters should be calculated by the formula

$$C = GV^2 / 127R$$

Where

G = Gauge of track + width of rail head in mm

V = Speed in kmph

R = Radius in m

C = Superelevation in mm

The permissible negative superelevation on the turnout (which is also the actual superelevation of the main line) may then be made as (75-C)mm.

ii) Curves of similar flexure:-

The question of reduction or otherwise of super-elevation on the mainline must necessarily be determined by the administration concerned. In the case of a reverse curve close behind the crossing of the turnouts, the superelevation may be run out at the maximum of 1mm in 360mm.

Length of sidings:

23 Minimum clear available length of one siding at any station where it is intended to cross trains:-

- i) Shall be length of longest train permitted in the section plus 35m
- ii) Although it may not be necessary till traffic develops to provide sidings for the largest possible train loads, land should be acquired for them and no building, level crossings or other obstructions should be permitted that will interfere with the crossing siding being lengthened to the following dimensions:-

| | |
|----------------------------------------------------------|--------------------------------------------------------------------------------------------|
| On sections of the railways where the Ruling gradient is | Minimum clear available length of one siding for new work or alterations to existing works |
| 1 in 100 or flatter | 750 m |
| Steeper than 1 in 100 | Length of the longest train permitted in the section plus 35 m |

Note: Clear Available length denotes:

- (i) Distance between foot of the signal to Fouling Mark in the rear on the same line in case of Main line and Directional Loop at station yard.
- (ii) In case of Common Loop at the stations, Clear Available Length/Clear Standing Length shall be the distance between two starter signals of opposite direction on the same line.

CHAPTER III - Workshops and station machinery

Water tanks and water cranes:

| | | | |
|---|------|-----------------------------------------------------------------------------------------------------------------|---------|
| 1 | (a) | Minimum height above rail level for discharge orifice of water crane | 3660mm |
| | (b) | Distance from centre of track to face of tank house less than 60 metres beyond the end of a passenger platform. | |
| | (i) | Minimum | 7165mm |
| | (ii) | Recommended | 11890mm |

Note:

- (a) Item 1(b) need not be observed in the case of small subsidiary or relay tanks which can easily be removed back to provide room for an extension of the yard.
- (b) Item 1(b)(i) allows for the extension of the platform and item 1(b) (ii) allows for the laying of an additional track and extending of the platform in future.
- (c) Minimum height for bottom of tank above rail level at water column:
 - (i) For watering engines 7620mm
 - (ii) For washing engines 12190mm
- (d) Minimum total tank capacity at any station 56.5 cum or 56825 litres
- (e) Minimum internal diameter for piping from tank to water crane 203mm

Workshops and running sheds:

| | | | |
|---|--------------------------------------------------|------------------------------------------------|--------|
| 2 | Minimum distance from centre to centre of tracks | | |
| | (i) | For existing works | 4570mm |
| | (ii) | For new works or alterations to existing works | |
| | (a) | In workshops | 4570mm |
| | (b) | In running sheds | 5260mm |

Note: Where there is a structure between tracks, the distance of centre to centre of tracks is to be increased by the amount of the width of the structure like O.H.E. post etc.

| | | | |
|---|--------------------------------------------------------------------------------------------|------------------------------------------------|--------|
| 3 | Minimum clear distance from centre of track to any isolated structure such as a pillar in: | | |
| | (i) | Workshops | |
| | (a) | For existing works | 2285mm |
| | (b) | For new works or alterations to existing works | 2360mm |

| | | |
|---|-----------------------------------------------------------------------------------------------------------------------|--------|
| | (ii) Running sheds | 2515mm |
| 4 | Minimum clear distance, for a height of 1830 mm above rail level, from centre of track to any continuous structure in | |
| | (i) Workshops | 2745mm |
| | (ii) Running sheds | 3275mm |

Note: For standard 'C' Railways, minimum horizontal distance for a height of 1830mm above rail level on either side of centre of track to any continuous structure in running sheds shall be 2745mm.

| | | |
|---|------------------------------------------------------------------------------------------------------------------------------------------|--------|
| 5 | Minimum height above rail level to overhead tie bars, girders etc. in workshops and running sheds: | |
| | (i) Where electric traction is not likely to be used | 5030mm |
| | (ii) Where electric traction is likely to be used | 6250mm |
| 6 | Minimum height above rail level of doorways for a width of 1370mm on either side of centre of track in both workshops and running sheds: | |
| | (i) Where electric traction is not likely to be used | 4875mm |
| | (ii) Where electric traction is likely to be used | 6250mm |

Ashpits etc.:

| | | |
|---|--------------------------------------------------------------------------------------------------|-------|
| 7 | Average depth for ashpits in station yards, pits in running sheds and carriage examination pits. | 760mm |
|---|--------------------------------------------------------------------------------------------------|-------|

Note: Siting of Ashpits on run through lines, should, if possible, be avoided.

Chapter IV(A) - Rolling Stock (Carriage & Wagon)

Wheels & Axles

| | | |
|---|-------------------------------------------------------------------------------------------------------------|----------------------------------|
| 1 | Wheel gauge, or distance apart, for all wheel flanges | Maximum 1602mm Minimum 1599mm |
| 2 | (i) Maximum diameter on the tread of new carriage or wagon wheel, measured at 63.5 mm from wheel gauge face | 1092mm |
| | (ii) Minimum diameter on the tread of new carriage or wagon wheel, measured at 63.5mm from wheel gauge face | 914mm |

Note: Minimum diameter on tread of new wagon wheel, measured at 63.5mm from wheel gauge face can be reduced to 840mm, subject to following conditions;

- (a) For operation of loaded wagons on curves sharper than 875m radius.
 - (i) On Grade 880 rail (as per IRS-T-12-2009 specification), speed restriction of 65kmph at axle load of more than 22t & up to 23t and of 45kmph at axle load more than 23t & up to 25t
 - (ii) On grade 1175HT rails, no speed restriction.
- (b) No speed restriction on curves flatter than 875m radius.
- (c) Limit of wheel flat 50mm for operation of loaded wagons at axle load more than 22t & up to 25t.

Note: For other rail grades and wheel diameters, separate study will be required.

| | | |
|---|--------------------------------------------------------------------------------------------------------|---------|
| 3 | Minimum projection for flange of New tyre, measured from tread at 63.5mm from wheel gauge face | 28.5mm |
| 4 | Maximum projection for flange of worn tyre, measured from tread at 63.5mm from wheel gauge face | 35.0mm |
| 5 | Maximum thickness of flange of tyre, measured from wheel gauge face at 13mm from outer edge of flange | 29.4mm |
| 6 | Minimum thickness of flange of tyre, measured from wheel gauge face at 13mm. from outer edge of flange | 16mm |
| 7 | Minimum width of tyre | 127mm |
| 8 | Incline of tread | 1 in 20 |

Height of Floors

| | | |
|---|---------------------------------------------------------------------------------------------------------------------------------------------|--------|
| 9 | Maximum height above rail level for floor of any unloaded vehicle including goods vehicle having side doors for platform loading/ unloading | 1345mm |
|---|---------------------------------------------------------------------------------------------------------------------------------------------|--------|

Note: Not applicable for goods vehicles not having side doors

| | | |
|----|------------------------------------------------------------------------------------------------|--------|
| 10 | Minimum height above rail level for floor of any fully loaded vehicle other than goods vehicle | 1200mm |
|----|------------------------------------------------------------------------------------------------|--------|

| | | |
|----|----------------------------------------------------------------------------------------------------------------------------------|--------|
| 11 | Minimum height above rail level for floor of any fully loaded goods vehicle which has side doors for platform loading/ unloading | 1145mm |
|----|----------------------------------------------------------------------------------------------------------------------------------|--------|

Note: Not applicable for goods vehicles not having side doors

Note: Maximum/Minimum floor height of such goods vehicle which does not have side doors for platform loading/ unloading, should be determined keeping in view the profile of the maximum moving dimension to diagram no. 1D particularly with respect to width of wagon at various heights.

Buffers & Couplings

| | | |
|----|-----------------------------------------------------------------------------------------------|--------|
| 12 | Distance apart for centers of buffers | 1956mm |
| 13 | Maximum height above rail level for centre of buffers & CBC couplers for unloaded vehicle | 1105mm |
| 14 | Minimum height above rail level for centre of buffers & CBC couplers for fully loaded vehicle | 1030mm |

Note: In case of wagons operated in unitization concept having different coupler heights, the maximum height of coupling line at the outer ends of the Unit shall be as per clause 13 & minimum height of coupling line at the outer ends of the Unit shall be as per clause 14. The minimum height of coupling line at other than outer ends shall not be less than 770mm in fully loaded condition and 845mm in unloaded condition.

Wheel Base & Length of Vehicles

| | | |
|----|--------------------------------------------------------------------|---------|
| 15 | Maximum rigid wheel base for four wheeled vehicles | 6100mm |
| 16 | Minimum distance apart of bogie centres for bogie vehicles | 5400mm |
| 17 | Maximum distance apart of bogie centres for bogie vehicles | 14900mm |
| 18 | (i) Minimum rigid wheel base for bogie truck of any vehicle | 1830mm |
| | (ii) Minimum rigid wheel base for bogie truck of passenger vehicle | 2440mm |
| 19 | Maximum length of body or roof for: | |
| | (a) 4- wheeled vehicle | 8540mm |
| | (b) Bogie vehicles | 21340mm |

Note:

- (i) Maximum length of body or roof of bogie vehicles can be upto 23540 mm, subject to tapering of the ends in a manner that the end throw, when calculated as per Appendix, is same as that for ICF coach of 21340 mm length and within this Schedule of Dimensions.
- (ii) A cornice may project beyond the maximum permissible length of the roof up to 51mm in the case of(a) above, beyond each end of the vehicle.

- (iii) Fittings on the end of a vehicle, such as step iron, vacuum brake piping, electrical connections, vestibule etc., need not be kept within the prescribed maximum permissible lengths for bodies of vehicles, but may project beyond the end of the body to a reasonable extent.

| | | |
|----|-------------------------------------------------------------|---------|
| 20 | Maximum length over centre buffer couplers or side buffers: | |
| | (a) 4 – wheeled vehicle | 9810mm |
| | (b) Bogie vehicles | 22300mm |

Note: Maximum length over the centre buffer couplers or side buffers can be increased up to 24000mm for Bogie Vehicles, in accordance to maximum length of body or roof. However, the maximum length over the centre buffer couplers or side buffers for longer coaches shall be so arranged that difference between length over side buffers and length of body or roof is not less than 460mm.

| | | |
|----|-------------------------------------------------------|---------|
| 21 | Maximum distance apart between any two adjacent axles | 12345mm |
|----|-------------------------------------------------------|---------|

Maximum Moving Dimensions (See diagram 1D)

| | | |
|----|---------------------------------------------------------------------------------------------------------------|---------------------------------------|
| 22 | Maximum width over all projections at 102mm above rail level, when fully loaded | 2440mm |
| 23 | Maximum width over all projections, at 305mm above rail level, when fully loaded | 3050mm |
| 24 | Maximum width over all projections from 305mm above rail level, to 940mm above rail level, when fully loaded | 3050mm |
| 25 | Maximum width over all projection from 940mm above rail level to 1082mm above rail level, when fully loaded | 3050mm increasing gradually to 3150mm |
| 26 | Maximum width over all projection from 1082mm above rail level, to 1170mm above rail level, when fully loaded | 3150mm increasing gradually to 3250mm |

Note: For freight bogie vehicles with maximum length of body or roof upto 14500mm and bogie centre distance upto 10000mm, maximum width overall projections from 305mm above rail level to 1060mm above rail level, when fully loaded, can be relaxed to 3135mm instead of 3050mm.

| | | |
|----|-------------------------------------------------------------------------------------------------------------------------------------------------------------------------------------------------------------------|--------|
| 27 | Maximum width over all projections from 1170mm above rail level, when fully loaded to a height of 3735mm when empty | 3250mm |
| | (i) Guttering, side lamps and destination boards may project 76 mm on each side beyond the dimensions given above from a height of 2895 mm to 3355 mm above rail level, upto a maximum over all width of 3402 mm. | |
| | (ii) Coach number plates may project 25mm on each side beyond the dimension given above from a height of 2590 mm to 2895mm above rail level, upto a maximum over all width of 3300mm. | |

- (iii) Reservation card holders may project 25mm on each side beyond the dimensions given above from a height of 1750 mm to 1980 mm above rail level upto a maximum over all width of 3300 mm.
- (iv) The doors are to be either sliding or opening inwards. Hand bolts, door locks, handles and window bars shall not, however, project beyond the dimensions given against item above.

28 Maximum width over open doors, including all projections for passenger vehicles 4040mm

29 Maximum width over open doors, including all projections for goods vehicles 4265mm

Note: Doors of horse boxes, brake vans, luggage vans and rising and falling flap doors of goods wagons are exempted from this rule.

30 Maximum height above rail level for a width of 1015mm on either side of the centre of unloaded vehicles 4265mm

31 Maximum height above rail level at sides of unloaded vehicles 3735mm

Note :

- i) Destination boards for passenger vehicles may project 76 mm above the dimensions upto a maximum height above rail level at sides of vehicles when empty.
- ii) (Applicable for clause 27, 28 & 31)

In case of stocks exceeding the 1929 profile and within the maximum moving dimensions shown in diagram 1D, clearance of the following railway is required to be obtained for the following locations before permitting the stock for the general adoption:

| S.No. | Railway | Section | Location |
|-------|---------------|----------------------|--------------------|
| 1 | 2 | 3 | 4 |
| 1. | E.Railway | Andal-Sainthia Chord | Br.No.66 |
| 2. | N.F.Railway | Old Malda -Singhabad | Tangon Br. |
| 3. | S.E.Railway | Tata-Rourkela | Up Saranda Tunnel |
| 4. | S.E.C.Railway | Bilaspur-Katni | Dn Bhortonk Tunnel |

32 Minimum height above rail level when fully loaded for a width of 1220mm on either side of centre of track with the exception of wheels and attachments thereto (vide note below) 91mm

Note: A tyre or an attachment of a wheel may project below the minimum height of 91 mm from a distance of 51 mm inside to 216 mm outside of the gauge face of the wheel.

| | | |
|----|------------------------------------------------------------------------------------|-------|
| 33 | Minimum height above rail level, when fully loaded at 1525 mm from centre of track | 305mm |
|----|------------------------------------------------------------------------------------|-------|

Loading Gauge for Goods

| | | |
|----|---------------|--------|
| 34 | Maximum width | 3250mm |
|----|---------------|--------|

| | | |
|----|-------------------------------------------|--------|
| 35 | Maximum height above rail level at center | 4265mm |
|----|-------------------------------------------|--------|

| | | |
|----|------------------------------------------|--------|
| 36 | Maximum height above rail level at sides | 3735mm |
|----|------------------------------------------|--------|

Note: The loading gauge is for testing loaded and empty vehicles; the maximum moving dimensions are given in items 27, 28, 30 and 31 above.

CHAPTER IV (B)

Rolling stock, 3660 mm wide stock

Note :

These dimensions shall not be adopted in designs for rolling stock without the special sanction of the Railway Board in each case.

Maximum future moving dimensions:

(See diagram No. 1-A)

| | | |
|-------|----------------------------------------------------------------------------------|--------|
| 1 | Maximum width over all projections: | |
| (i) | At 102mm above rail level, when fully loaded | 2895mm |
| (ii) | At 305mm above rail level, when fully loaded | 3505mm |
| (iii) | From 305mm above rail level to 1145mm above rail level when fully loaded | 3505mm |
| (iv) | From 1145mm above rail level, when fully loaded to a height of 3355mm when empty | 3660mm |
| (v) | At 4265mm above rail level, when empty | 3505mm |

2 Maximum width over open doors, including all projections, for passenger vehicles 4495mm

3 Maximum width over open doors, including all projections, for goods vehicles 4500mm

Note: Doors of horse boxes, brake vans, luggage vans and rising and falling flap doors of goods wagons are exempted from this rule.

4 Maximum height above rail level for a width of 915mm on either side of the centre of unloaded vehicles 4725mm

5 Maximum height above rail level at sides of unloaded vehicles 4265mm

6 Minimum height above rail level, when fully loaded for a width of 1450mm on either side of centre of track, with the exception of wheels and attachments thereto (vide note below) 102mm

Note: A tyre or an attachment to a wheel may project below the minimum height of 102mm from a distance of 51mm inside to 216mm outside of the gauge face of the wheel.

7 Minimum height above rail level, when fully loaded at 1755mm from centre of track 305mm

Loading gauge for goods:

8 (i) Maximum width at a height of 3380mm above rail level 3710mm
(ii) Maximum width at a height of 4295mm above rail level 3555mm

9 Maximum height above rail level for a width of 915mm on either side of the centre of track 4750mm

10 Maximum height above rail level at sides 4295mm

Note: The loading gauge is for testing loaded and empty vehicles, the maximum moving dimensions are given in items 1(iv), 4 and 5 above.

Chapter IV (C) Rolling Stock (Locomotive)

Wheel and axles:

| | | | |
|---|----------------------------------------------------------------------------------------------------------------|--------|------|
| 1 | Wheel gauge or distance apart for wheel flanges: | | |
| | (a) Wheels with thick flanges/wear adopted wheel profile | 1596mm | |
| | (b) Wheels with standard flanges | 1600mm | |
| | (c) Wheels with thin flanges | 1600mm | |
| | (d) Wheels without flanges | 1600mm | |
| | (See item 5 for identification of thick/wear adopted, standard & thin flanges) | | |
| 2 | (i) Maximum diameter on the tread of new locomotive carrying wheels measured at 63.5mm from wheel gauge face | 1250mm | |
| | (ii) Minimum diameter on the tread of new locomotive carrying wheels measured at 63.5mm from wheel gauge face. | 914mm | |
| 3 | Minimum projection for flange of new tyre measured from tread at 63.5mm from wheel gauge face | 28.5mm | |
| 4 | Maximum projection for flange of worn tyre measured from tread at 63.5mm from wheel gauge face | 35mm | |
| 5 | Maximum and minimum thicknesses of tyre flanges measured at 13mm from outer edge of flange: | | |
| | | Max. | Min. |
| | (a) Thick flanges/wear adopted wheel profile | 32mm | - |
| | (b) Standard flanges | 28mm | - |
| | (c) Thin flanges | 18mm | - |

Note:

- (i) The above values of flange thicknesses are measured from the back face of the tyre.
 - (ii) Minimum size of flange of locomotive tyres shall be determined by condemning profile gauge which specifies the minimum thickness and the limits of angularity of the flange on the gauge face.
- | | | |
|---|------------------------------------------|-------|
| 6 | Minimum width of tyres: | |
| | (a) Locomotive coupled wheels | 133mm |
| | (b) Locomotive wheels other than coupled | 127mm |
- | | | |
|---|------------------|---------------------------------------------------------------------------------------------------------------------------------------------------|
| 7 | Incline of tread | 1 in 20 for all profiles except wear adopted profile for which the tread inclination of 1 in 20 will merge with radii of the wear adopted profile |
|---|------------------|---------------------------------------------------------------------------------------------------------------------------------------------------|

Buffers & Couplings:

| | | |
|----|-----------------------------------------------------------------------------------|--------|
| 8 | Distance apart for centres of buffers | 1956mm |
| 9 | Maximum height above rail level for centres of buffers & CBC for empty locomotive | 1105mm |
| 10 | Minimum height above rail level for centres of buffers & CBC when fully loaded | 1030mm |

Maximum Moving Dimensions:

(see New Diagrams 1D)

| | | |
|-----|--------------------------------|---------|
| 11. | Maximum length of body or roof | 21340mm |
|-----|--------------------------------|---------|

Note: Maximum length of body or roof can be upto 23540mm, subject to tapering of the ends in a manner that the end-throw, when calculated as per Appendix, is same as that for ICF coach of 21340mm length and within this Schedule of Dimensions.

| | | |
|----|------------------------------------------------------------|---------|
| 12 | Maximum length over centre buffer couplers or side buffers | 22300mm |
|----|------------------------------------------------------------|---------|

Note: Maximum length over the centre buffer couplers or side buffers can be increased upto 24000mm for Bogie Vehicles, in accordance to maximum length of body or roof. However, length over the centre buffer couplers or side buffers be so arranged that difference between length over side buffers and length of body or roof is not less than 460mm.

| | | |
|-----|---------------------------------------------------------------------------------------------------------|---------------------------------------|
| 13. | Maximum width over all projections: | |
| | (i) At 91mm above rail level, when fully loaded | 2440mm |
| | (ii) At 91mm to 305mm above rail level, when fully loaded | 2440mm increasing gradually to 3050mm |
| | (iii) From 305mm above rail level, to 940mm above rail level, when fully loaded | 3050mm |
| | (iv) From 940mm above rail level, to 1082mm above rail level, when fully loaded | 3050mm increasing gradually to 3150mm |
| | (v) From 1082mm above rail level, to 1170mm above rail level, when fully loaded | 3150mm increasing gradually to 3250mm |
| | (vi) From 1170mm above rail level, when fully loaded to a height of 3735mm above rail level, when empty | 3250mm |

Note: (i) Maximum width over all projections from 925mm (minimum in all conditions) above rail level to 1082mm above rail level, when fully loaded can be 3075mm (in the bogie portion only).

(ii) Maximum distance apart of bogie centres (i.e. pivot centres) for locomotives shall be 15810mm, subject to the condition that width of locomotive at the centre is such that mid-throw, when calculated as per Appendix, is same as that for ICF coach of 21340mm length and within this Schedule of Dimensions.

| | | |
|----|--------------------------------------------------------------------------------------------------------|--------|
| 14 | Maximum height above rail level for a width of 1015mm on either side of the centre of unloaded vehicle | 4265mm |
| 15 | Maximum height above rail level at sides of empty locomotives | 3735mm |

Maximum Moving Dimensions for X-Class locomotives

| | | |
|----|----------------------------------------------------------------------------------------------------------|------------------------------------------------|
| 16 | Maximum width overall projections | |
| | (i) At 102mm above rail level, when fully loaded | 2440mm |
| | (ii) From 305 mm above rail level to 1110 mm above rail level, when fully loaded | 3135mm |
| | (iii) From 1110mm above rail level to a height of 1145mm above rail level, when fully loaded | 3135mm increasing gradually to 3200mm |
| | (iv) From 1145 mm above rail level when fully loaded to a height of 3735 mm above rail level, when empty | 3200mm |

| | | |
|----|---------------------------------------------------------------------------------------------------|--------|
| 17 | Maximum height above rail level for width of 305 mm on either side of centre of empty locomotives | 4470mm |
|----|---------------------------------------------------------------------------------------------------|--------|

Note: The dimension given in item no. 17 shall not be adopted without obtaining prior approval of Railway Board.

| | | |
|----|-----------------------------------------------------------------------------------------------------------------------------------------------------------------------------------|--------|
| 18 | Maximum height above rail level at sides of empty locomotives | 3735mm |
| 19 | Minimum height above rail level when fully loaded for a width of 1220 mm on either side of centre of track with the exception of wheels and attachments thereto (vide note below) | 91mm |

Note: A tyre or an attachment to a wheel or sand pipes in line with the wheel may project below the minimum height of 91mm from a distance of 51mm inside to 216 mm outside of the gauge face of the wheel.

| | | |
|----|-----------------------------------------------------------------------------------|-------|
| 20 | Minimum height above rail level when fully loaded at 1525 mm from centre of track | 305mm |
|----|-----------------------------------------------------------------------------------|-------|

Chapter IV (D) - Rolling Stock (Track Machines)

Note: Any Rail bound vehicle used for track laying and track maintenance will be treated as Track Machines. Provisions under this chapter shall be applicable for Track machines.

Wheels & Axles

| | | |
|---|-------------------------------------------------------------------------------------------------------------|----------------------------------|
| 1 | Wheel gauge, or distance apart, for all wheel flanges | Maximum 1602mm Minimum 1599mm |
| 2 | (i) Maximum diameter on the tread of new carriage or wagon wheel, measured at 63.5 mm from wheel gauge face | 1092mm |
| | (ii) Minimum diameter on the tread of new carriage or wagon wheel, measured at 63.5mm from wheel gauge face | 730mm |
| 3 | Minimum projection for flange of New tyre, measured from tread at 63.5mm from wheel gauge face | 27.5mm |
| 4 | Maximum projection for flange of worn tyre, measured from tread at 63.5mm from wheel gauge face | 35.0mm |
| 5 | Maximum thickness of flange of tyre, measured from wheel gauge face at 13mm from outer edge of flange | 32mm |
| 6 | Minimum thickness of flange of tyre, measured from wheel gauge face at 13mm. from outer edge of flange | 16mm |
| 7 | Minimum width of tyre | 127mm |
| 8 | Incline of tread | 1 in 20 |

Height of Floors

| | | |
|----|-----------------------------------------------------------------------|--------|
| 9 | Maximum height above rail level for floor of unloaded vehicle | 2100mm |
| 10 | Minimum height above rail level for floor of any fully loaded vehicle | 1145mm |

Buffers & Couplings

| | | |
|----|--------------------------------------------------------------------------------------------|--------|
| 11 | Distance apart for centers of buffers | 1956mm |
| 12 | Maximum height above rail level for centres of buffers & CBC couplers for unloaded vehicle | 1105mm |
| 13 | Minimum height above rail level for centers of buffers & CBC couplers when fully loaded | 1030mm |

Wheel Base & Length of Vehicles

14 Maximum rigid wheel base for four wheeled vehicles 6100mm

Note: Maximum rigid wheel base can be upto 8000mm subject to maximum speed in train formation shall be 60kmph. Speed restriction on other aspects has not been considered.

15 Minimum distance apart of bogie centres for bogie vehicles 5400mm

16 Maximum distance apart of bogie centres for bogie vehicles 16000mm

Note: Maximum distance apart of bogie centres for bogie vehicle more than 14900 mm shall be permitted, subject to the condition that mid-throw, when calculated as per Appendix, shall be same or less as that for ICF coach of 21340mm length and within this Schedule of Dimensions.

17 Minimum rigid wheel base for bogie truck of any vehicle 1800mm

18 Maximum length of body or roof for:

(a) 4- wheeled vehicle 8540mm

Note: Maximum length of body or roof can be upto 13590mm, subject to maximum speed in train formation shall be 60kmph. Speed restriction on other aspects has not been considered.

(b) Bogie vehicles 21340mm

Note: (i) In case of single unit, maximum length of body or roof can be upto 23540mm, subject to tapering of the ends in a manner that the end-throw, when calculated as per Appendix, is same as that for ICF coach of 21340mm length and within this Schedule of Dimensions.

(ii) In case of two unit of Track Machines coupled together and working as one unit, maximum length of body or roof can be upto 38200mm, subject to in a manner that the end throw, when calculated as per Appendix, is same as that for ICF coach of 21340mm length and within this Schedule of Dimensions.

19 Maximum length over centre buffer couplers or side buffers:

(a) 4 – wheeled vehicle 9810mm

Note: Maximum length over centre buffer couplers or side buffers can be upto 14780mm, subject to maximum speed in train formation shall be 60kmph. Speed restriction on other aspects has not been considered.

(b) Bogie vehicles 22300mm

Note: (i) In case of single unit, maximum length over the centre buffer couplers or side buffers can be increased upto 24000mm for Bogie Vehicles, in accordance to maximum length of body or roof. However, length over the centre buffer couplers or side buffers be so arranged that difference between length over side buffers and length of body or roof is not less than 460mm.

(ii) In case of two unit of Track Machines coupled together and working as one unit, maximum length over the centre buffer couplers or side buffers can be increased up to 39440mm, subject to in a manner that the end throw for each unit, when calculated as per Appendix, is same as that for ICF coach of 21340 mm length and within this Schedule of Dimensions.

| | | |
|----|-------------------------------------------------------|---------|
| 20 | Maximum distance apart between any two adjacent axles | 14170mm |
|----|-------------------------------------------------------|---------|

Note: Maximum distance apart of any two adjacent axles more than 12345 mm shall be permitted, subject to the condition that mid-throw, when calculated as per Appendix, is same or less as that for ICF coach of 21340mm length and within this Schedule of Dimensions.

Maximum Moving Dimensions (See diagram 1D)

| | | |
|----|-----------------------------------------------------------------------------------------------------------------------------------------------------------------------------------------------|---------------------------------------|
| 21 | Maximum width over all projections at 91mm above rail level, when fully loaded | 2440mm |
| 22 | Maximum width over all projections, at 305mm above rail level, when fully loaded | 3050mm |
| 23 | Maximum width over all projections from 305mm above rail level, to 940mm above rail level, when fully loaded | 3050mm |
| 24 | Maximum width over all projection from 940mm above rail level to 1082mm above rail level, when fully loaded | 3050mm increasing gradually to 3150mm |
| 25 | Maximum width over all projection from 1082mm above rail level, to 1170mm above rail level, when fully loaded | 3150mm increasing gradually to 3250mm |
| 26 | Maximum width over all projections from 1170mm above rail level, when fully loaded to a height of 3735mm when empty | 3250mm |
| | (i) Guttering and side lamps may project 76 mm on each side beyond the dimensions given above from a height of 2895 mm to 3355 mm above rail level, upto a maximum over all width of 3402 mm. | |
| | (ii) The doors are to be either sliding or opening inwards. Hand bolts, door locks, handles and window bars shall not, however, project beyond the dimensions given against item above. | |
| 27 | Maximum width over open doors, including all projections for vehicles | 4265mm |
| 28 | Maximum height above rail level for a width of 1015mm on either side of the centre of unloaded vehicles | 4265mm |
| 29 | Maximum height above rail level at sides of unloaded vehicles | 3735mm |

Note:

In case of stocks exceeding the 1929 profile and within the maximum moving dimensions shown in diagram 1D, clearance of the following railway is required to be obtained for the following locations before permitting the stock for the general adoption:

| S.No. | Railway | Section | Location |
|--------------|----------------|----------------------|--------------------|
| 1 | 2 | 3 | 4 |
| 1. | E. Railway | Andal-Sainthia Chord | Br.No.66 |
| 2. | N.F. Railway | Old Malda -Singhabad | Tangon Br. |
| 3. | S.E. Railway | Tata-Rourkela | Up Saranda Tunnel |
| 4. | S.E.C. Railway | Bilaspur-Katni | Dn Bhortonk Tunnel |

30 Minimum height above rail level when fully loaded for a width of 1220mm on either side of centre of track with the exception of wheels and attachments thereto (vide note below) 91mm

Note: A tyre or an attachment of a wheel may project below the minimum height of 91 mm from a distance of 51 mm inside to 216 mm outside of the gauge face of the wheel.

31 Minimum height above rail level, when fully loaded at 1525 mm From centre of track 305mm

CHAPTER V - ELECTRIC TRACTION (Direct Current)

Note: Wherever electric traction, employing overhead conductor wires, is in use strict orders must be issued prohibiting any one from getting on the roofs of vehicles until the current in the overhead conductors has been switched off and the conductors themselves have been earthed.

| | | |
|-------|--------------------------------------------------------------------------|--------|
| 1 | Minimum height from rail level to the underside of live conductor wire:- | |
| (i) | Under bridges and tunnels | 5030mm |
| (ii) | In the open | 5335mm |
| (iii) | In running and carriage sheds | 5790mm |
| (iv) | At level crossing | 5485mm |

Note: The height prescribed in item 1(iv) applies also to tramway trolley wires crossing the railway.

| | | |
|---|-----------------------------------------------------------------------------------------------------------|--------|
| 2 | Maximum height from rail level to the underside of live contact wire except in running and carriage sheds | 5790mm |
|---|-----------------------------------------------------------------------------------------------------------|--------|

Note: In the case of running and carriage sheds, the maximum height of the contact wire will be determined in each case based on the operating range of the pantograph and the permissible electrical clearances required inside the sheds.

| | | |
|------|--------------------------------------------------------------------------------------|--------|
| 3 | Maximum variation of live conductor wire on either side of the central line of track | |
| (i) | On straight track | 230mm |
| (ii) | On curves (on the inside of the curve) | 380mm |
| 4 | Minimum distance between live conductor wire and any structure | 130mm |
| 5 | Maximum width of pantograph collector | 2030mm |

CHAPTER V (A) Electric Traction

25 kV A.C. 50 Cycles

Note: Wherever electric traction is in use, special precautions shall be taken in accordance with provisions made in chapter XVII of 'General Rules' for all Open lines of Railways.

Electrical clearances:

1 Vertical and lateral distance between 25 kV live parts and earthed parts of fixed structures or moving loads/rolling stocks shall be as large as possible. The minimum vertical and lateral electrical clearances to be maintained under worst condition of temperature, wind etc. between any live part of the overhead equipment or pantograph and parts of any fixed structures (earthed or otherwise) or moving loads/rolling stocks shall be as under :

| | | |
|------|----------------|-------|
| (i) | Long duration | 250mm |
| (ii) | Short duration | 200mm |

- Note:** (a) Long Duration means when the conductor is at rest and short duration means when the conductor is not at rest.
- (b) A minimum vertical distance of 270 mm shall normally be provided between rolling stock and contact wire to allow for a 20 mm temporary raising of the track during maintenance. Wherever the allowance required for track maintenance exceed 20 mm, the vertical distance between rolling stock and contact wire shall correspondingly be increased.
- (c) Where adoption of above clearances is either not feasible or involves abnormally high cost, Permanent Bench Mark shall be provided to indicate the level of track to be maintained.

2 Minimum height from rail level to the underside of contact wire :

| | | |
|-------|-------------------------------|------------|
| (i) | Under Bridges and in Tunnels | 4.80 metre |
| (ii) | In the open | 5.50 metre |
| (iii) | At level crossings | 5.50 metre |
| (iv) | In Running and Carriage Sheds | 5.80 metre |

Note:

- (a) In cases where it is proposed to allow Locomotives or Rolling stocks not higher than 4.42 m, the minimum height of Contact Wire, specified under item 2(i) above may be reduced to 4.69 metre.
- (b) In cases, where it is proposed to allow only Locomotive or Rolling Stocks not higher than 4.27m, the minimum height of contact wire, specified under Item 2(i) above may be reduced to 4.54m. A board showing this restriction and specifying "locomotives or Stocks not permitted to ply on such section" shall be exhibited at the entrance to the same.
- (c) For movement of Over Dimensional consignments, the height specified under Item 2(i) above shall be increased by the difference between the height of the consignment contemplated and 4.42m. In case, such an over dimensional consignment is moved at speed not exceeding 15Km/h and is also specially escorted by authorized Railway Staff, the derived height of Contact Wire may be reduced by 50 mm.

- (d) On curves, all vertical distances specified in Item (2) above, shall be measured above the level of the inner rail, increased by half the super-elevation.
- (e) Suitable prescribed gradient on the height of contact wire shall be provided for connecting these wires installed at different heights.

3 Maximum variation in alignment of the live Conductor Wire on either side of the centre line of track under static condition:

- | | | |
|------|-------------------|--------|
| (i) | On straight track | 200 mm |
| (ii) | On curves | 300 mm |

Note: These limits would not apply to special locations e.g. Insulated Overlaps and Out of Run Wires.

- | | | | |
|---|------|---------------------------------------------------------------------------------------------------------------------------------|----------|
| 4 | (i) | Maximum width of pantograph collector | 2030mm |
| | (ii) | When DC traction is converted to 25 kV AC traction, width of Pantograph collector {subject to it being within the approved MMD} | : 2030mm |

Note: A tolerance of plus 10 mm on maximum width specified is permissible to accommodate variation in manufacture and mounting with respect to the centre line of vehicle.

5 In the case of light structures such as foot-over bridges, it would be desirable to keep a standard height of contact wire of 5.50m. In case of heavy structures, such as flyover bridges or Road over bridges, it is desirable to keep the height of contact wire as low as possible, consistent with the requirements of movement of Standard Class 'C' Over-Dimensional Consignments of height 4.80m.

CHAPTER V-B - 25 kV A.C. Electric Traction with High Rise OHE

Note: Provisions under this chapter are applicable only for electrification of routes where double stack container having maximum height of 6809 mm ~~6827 mm~~ is ~~are~~ plying.

1. Minimum Height from rail level to the underside of contact wire in open: 7520mm ~~7220mm~~

Note: On curves, the height shall be measured from the higher or super elevated rail.

2. Minimum Height of Overhead structure above rail level for a distance of 1600 mm on either side of the centre of track shall be as under:

(A) Light Overhead Structures, such as Foot Over Bridges: 8430mm ~~8250mm~~

(B) Heavy Overhead Structures, such as Road Over Bridges and Flyovers: 8050mm ~~7870mm~~

(C) Heavy Overhead Structures, such as Road Over Bridges and Flyovers, if any turnout or crossover is located under that heavy overhead structure or within 40 meters from its nearest face: ~~8430mm~~ ~~8250mm~~

Note:

(i) Necessary provision shall be made in overhead structure and overhead equipment to permit an extra allowance for raising of track in future to cater for modern track structure in the form of increased ballast cushion of 350 mm, larger sleeper depth of 230 mm and heavier rail sections of 200 mm including 10 mm thick rubber pad by using longer traction overhead equipment masts, if necessary.

(ii) In case of restricted height of existing overhead structures, minimum height of overhead structure for a distance of 1600mm on either side of the centre of track for provision of high rise OHE as per note (iii) below, to permit operation of double stack container having maximum height as ~~6809 mm~~ ~~6827 mm~~ shall be as under:

(a) Light Overhead Structures, such as Foot Over Bridges: 7568mm ~~7586mm~~

(b) Heavy Overhead Structures, such as Road Over Bridges and Flyovers: 7468mm ~~7486mm~~

(c) Heavy Overhead Structures, such as Road Over Bridges and Flyovers, if any turnout or crossover is located under that heavy overhead structure or within 40 m from its nearest face: 7568mm ~~7586mm~~

For these minimum restricted heights, catenary wire shall be terminated outside overhead structure (Road Over Bridges & Flyovers / Foot Over Bridges).

(iii) In case of restricted height of existing overhead structures, bridges and tunnels as mentioned in (ii) above, the minimum height of underside of the contact wire from rail level can be reduced to ~~7466mm~~ ~~7184 mm~~. In such cases, a special study shall be made, before 25 kV AC traction is introduced as explained below:

- (a) Height of the rolling stock: 6809mm **6827mm**
- (b) Short duration electrical clearance: 200mm
- (c) Additional electrical clearance for oscillation of the contact wire (For OHE span length of 49.5m or below): 50mm
- (d) Allowance for track upgradation/maintenance: 50mm
- (e) Rise in rolling stock height under dynamic conditions: 57mm
- (f) Minimum height of contact wire: 7166mm **7184mm**

(ACS No.01 dated 18.10.2022)

(iv) Extra vertical clearance shall be provided on curves as under:

$$\text{Extra vertical clearance (mm)} = \frac{\text{Width of MMD (mm)} \times \text{Super elevation (mm)}}{\text{Dynamic gauge (mm)}}$$

This extra vertical clearance on curve would be with respect to inner rail of curve.

3. Clearance for Power Line Crossings Including Telephone Line Crossings of Railway Tracks:

| SL | Over Head Crossing Voltage | Minimum Clearances From Rail Level | | Minimum Clearance Between Highest Traction Conductor and Lowest Transmission Line Crossing Conductor |
|-----|----------------------------|------------------------------------------------------------|------------------------------------------------------------|------------------------------------------------------------------------------------------------------|
| | | Existing Power Line Crossing For Non-Electrified Territory | New Power Line Crossing or Crossing Planned For Alteration | |
| (1) | (2) | (3) | (4) | (5) |
| (a) | Upto and including 11kV | Normally By Underground Cable | | |
| (b) | Above 11kV & upto 33kV | 10860mm | 16660mm | 2440mm |
| (c) | Above 33kV & upto 66kV | 11160mm | 16960mm | 2440mm |
| (d) | Above 66kV & upto 132kV | 11760mm | 17560mm | 3050mm |
| (e) | Above 132kV & upto 220kV | 12660mm | 18460mm | 4580mm |
| (f) | Above 220kV & upto 400kV | 14460mm | 20260mm | 5490mm |
| (g) | Above 400kV & upto 500kV | 15360mm | 21160mm | 7940mm |
| (h) | Above 500kV & upto 800kV | 18060mm | 23860mm | 7940mm |

Note:

- (i) All height/clearances are in mm and under maximum sag conditions.
- (ii) If the crossing is provided with a guarding, a minimum clearance of 2000mm shall be maintained between bottom of the guard wire and highest traction conductor.

(iii) Power line crossing in yards & stations area shall be avoided.

(iv) For electrification works of existing track or construction of new track/ gauge conversion with electrification, existing power line crossings can continue, if dimensions are as per Column (5) above, even if dimensions of Col (3) are not satisfied i.e. for electrification works Col (3) is not applicable.

4. Maximum width of Pantograph Collector:

2030 mm

Note: A tolerance of plus 10mm on maximum width specified is permissible to accommodate variation in manufacture and mounting with respect to centre line of vehicle.

SCHEDULE - II

Existing infringements of schedule I which may be permitted to continue on existing 1676 mm gauge Railways.

The following infringements of the dimensions prescribed in schedule I may, subject to such restrictions of speed as are considered necessary, be permitted on existing railways (see diagram No. 3) it being understood that when structures are altered they will be rebuilt to comply with schedule I, except in case of structures falling under item 7.

Dimensions marked (a) refer to the requirements for 3250 mm wide stock [chapter IV(A) of schedule I], and those marked (b) refer to the requirements for 3660 mm wide and 4725 mm high stock (chapter IV(B) of Schedule I)

| | | | |
|----|-----|---------------------------------------------------------------------------------------------------------------------------------------|--------|
| 1. | (a) | Minimum distance centre to centre of tracks | 3660mm |
| | (b) | Minimum distance centre to centre of tracks | 4040mm |
| 2. | (a) | Minimum clear horizontal distance from centre of track to any fixed structure from rail level to 1065mm above rail level | 1675mm |
| | (b) | Minimum clear horizontal distance from centre of track to any fixed structure from rail level to 1065mm above rail level | 1905mm |
| 3. | (a) | Minimum clear horizontal distance from centre of track to any fixed structure from 1065mm above rail level to 3505mm above rail level | 1980mm |
| | (b) | Minimum clear horizontal distance from centre of track to any fixed structure from 1065mm above rail level to 3355mm above rail level | 2135mm |
| 4. | (a) | Minimum clear horizontal distance from centre of track at 4265mm above rail level | 2055mm |
| 5. | (a) | Minimum clear height above rail level for a distance of 305mm on either side of centre of track. | 4420mm |
| | (b) | Minimum clear height above rail level for a distance of 915mm on either side of centre of track. | 5030mm |

Note:

- i) Items 2(a), 3(a), 3(b) and 4(a) refer to structures outside station yards only.
- ii) Where speed is restricted to 16 km/h, the minimum clear horizontal distance under 4(a) may be reduced to 1980 mm.
- iii) Where, as on girder bridges, ashpits, etc., the structure is not likely to be out of plumb and the super-elevation (or level of rails) does not vary and where the speed is restricted to 16 km/h, the above dimensions may be reduced to:
 3580 mm for 1(a), 3960 mm for 1(b),
 1905 mm for 3(a), 2055 mm for 3(b),
 1980 mm for 4(a),
 4265mm for 5(a), 4875 mm for 5(b)
- (iv) To the horizontal distance given in 1 to 5 must be added the extra allowance for curves (See Appendix). Where existing structures do not permit of these allowances being given, they may be

reduced by limiting the superelevation to be allowed for outer over inner rail. When this is done a notice board should be erected against the structure, stating the maximum permissible superelevation.

6. The minimum permissible clearances in existing tunnels and girder bridges shall be:

i) Under any circumstances and subject to any restriction of speed which it may be considered necessary to impose:

| | | In tunnels (See Diagram No.3) | On girder bridges |
|----|-----|----------------------------------|-----------------------------------|
| At | `A' | 229mm | 229mm at top of sides of vehicles |
| | `B' | 305mm | 229mm at side of vehicles |
| | `C' | 380mm | 305mm between moving trains |
| | `D' | 229mm | 152mm above vehicles |

ii) For unrestricted speeds:

| | | In tunnels | On Girder Bridges |
|----|-----|------------|-----------------------------------|
| At | `A' | 380mm | 229mm at top of sides of vehicles |
| | `B' | 535mm | 455mm at sides of vehicles |
| | `C' | 610mm | 535mm between moving trains |
| | `D' | 305mm | 229mm above vehicles. |

Where doors opening inwards or of the recessed or sliding type are provided the minimum clearances in tunnels and bridges may be reduced to 380 mm, at `B' and 455 mm at `C' for unrestricted speed. To the above must be added the extra allowance for curves (See Appendix).

7. Structures which have already been built in accordance with items 10 and 13 of chapter I, items 9,10 and 11 of chapter II and items 5 and 6 of chapter III of Schedule I as contained in the 1958 reprint, reproduced in note below, may infringe the dimensions now shown against these items. Such infringements may continue and alterations for the removal of such infringements need be taken up only when 25 K.V. A.C. Electric Traction is undertaken when a study shall be made of each structure to limit the extent of alterations as indicated in Appendix A to chapter V-A.

Note: The above items as reproduced below are not minimum dimensions of Schedule -II. The minimum dimensions of Schedule-II are as mentioned in items 1 to 6, 8 and 9 of Schedule –II.

Item 10 chapter I, Schedule I

Minimum height above rail level for a distance of 915 mm on either side of the centre of track for overhead structure 4875mm

Note: See Appendix for 'extra clearance required on curves'

Item 13, Chapter I Schedule I

(i) Minimum distance centre to centre of tracks 4725mm

Note: When respacing existing lines, the minimum distance centre to centre of tracks may be reduced from 4725 mm to not less than 4495 mm for the purpose of avoiding heavy alterations to tunnels or through or semi through girder bridges. The 4725 mm dimension is to be adopted for all new works.

(ii) Minimum horizontal distance from centre of track to any structure shall be as follows:

| Height above rail level | Horizontal distance from centre of track |
|--------------------------|------------------------------------------|
| a) From 0 to 305 mm | 1905 mm |
| b) From 305mm to 1065mm | 1905 mm increasing to 2360mm |
| c) From 1065mm to 3355mm | 2360 mm |
| d) From 3355mm to 4420mm | 2360 mm decreasing to 2135mm |
| e) From 4420mm to 5410mm | 2135 mm decreasing to 915mm |

Note:

- a) Where electric traction is not likely to be used overhead bracing of bridges may be 5030 mm above rail level for a distance of 1370mm on either side of centre of track.
- b) See Appendix for extra clearance required on curves.

Item 9, chapter II, schedule. I

Minimum height above rail level for a width of 1370mm on either side of the centre of track, of tie rods or any continuous covering in a passenger station. 6100mm

Note: Item 9 does not apply to overhead piping parallel to the track.

Item 10, Chapter II, Schedule I

Minimum height above rail level for a width of 1370mm on either side of the centre of track of a signal gantry or a foot over bridge in passenger station 4875mm

Note:

- (a) This also applies to overhead piping arrangements parallel to track wherever provided which shall necessarily be changed over to the ground hydrants when the section is electrified.

Item 11, chapter II, Schedule I

| | |
|-------------------------------------------------------------------|-----------------------------|
| Minimum horizontal distance from centre of track to any structure | |
| (i) From rail level to 305mm above rail level | 1675mm |
| (ii) From 305mm above rail level to 3355mm above rail level | 2135mm |
| (iii) From 3355mm above rail level to 4115mm above rail level | 2135mm decreasing to 1980mm |
| (iv) From 4115mm above rail level to 6100mm above rail level | 1370mm |

Note: See Appendix for clearance required on curves.

Item 5, Chapter III, Schedule I

Minimum height above rail level to overhead tie bars, girders etc in workshops and running sheds

- | | | |
|------|--------------------------------------------------|--------|
| (i) | Where electric traction is not likely to be used | 5030mm |
| (ii) | Where electric traction is likely to be used | 6176mm |

Item 6, Chapter III, Schedule I

Minimum height above rail level of doorways for a width of 1370mm on either side of centre of track, in both workshops and running sheds

- | | | |
|------|--------------------------------------------------|--------|
| (i) | Where electric traction is not likely to be used | 4875mm |
| (ii) | Where electric traction is likely to be used | 6176mm |

A.C Traction 25 K.V. 50 cycles

8. General: For tunnels & through girder bridges.

| | |
|-----------------------------------------------------------------------------------------------------------|----------------------------|
| Minimum horizontal distance from centre of track to any structure from 4420mm to 5410 mm above rail level | 2135mm decreasing to 915mm |
|-----------------------------------------------------------------------------------------------------------|----------------------------|

Note: See Appendix for extra clearance required on curves.

- | | |
|---------------------------------------------------------------------------------------------------------------|--------|
| 9. Minimum horizontal distance from centre of track to any structure from 4115 mm to 6100 mm above rail level | 1370mm |
|---------------------------------------------------------------------------------------------------------------|--------|

Note: See Appendix for extra clearance required on curves.

APPENDIX

Note:

- a) Column 5 applies to goods platforms 1065 mm above rail level which are not on a running line. For such platforms on running lines 25mm should be added to the figures given in column 5.
- b) Where electric traction is likely to be used, add 1mm for every 12mm of height above 5410 to the figures given in the column 7 upto the height at which the conductor wires are likely to be fixed.
- c) Where there is a structure between tracks, the extra clearance to be provided must be according to columns 5, 6, 7 and 8 instead of column 9.
- d) Appendix showing extra clearance on curves has been revised. In the revised table, the maximum permissible speed and corresponding superelevation are indicated and the required clearances based on these superelevations have been given.

Note on Extra Clearance on Curves

1. It has been contended that the extra clearance prescribed for curves both in the 1913 and in the 1922 Schedule of Dimensions was too liberal in the case of platforms, and caused a gap between the platform and foot board at certain parts of a bogie carriage, which was dangerous to passengers. In the 1922 schedule, the allowance for lurching and sway of the carriage was treated as entirely additional to that already provided for such motion in the clearance given for straight platforms whereas only additional sway due to the curved track in excess of the maximum occurring on straight track need be provided for. The amount of superelevation allowed for was also excessive on the sharper curves.
2. The clearance provided between a vehicle (i.e. the foot boards) and the platform coping on the straight is 152mm. It is considered that to reduce the average distance between a curved platform and the foot boards the minimum clearance between a platform on the outside of a curve and the ends of a vehicle may safely be reduced to 127mm. The maximum movement due to lurching at the centre of a vehicle cannot be greater than seven tenth of that at the ends, so that the minimum clearance between the centre of a vehicle and a platform on the inside of a curve may be safely reduced to 102mm. Therefore, in calculating the extra allowance to be provided on curves as explained in paragraph 5, 6, 7 and 8, a reduction of these extra allowance has been made of 51mm on the inside and 25mm on the outside of curve as shown in paragraph 7.
3. Allowance to be made:- The additional clearance to be given on the inside of a curve must include the effect of curvature, the lean due to superelevation, and an allowance for any additional sway of the vehicles over that already provided for in the clearance on straight tracks. The additional clearance to be given on the outside of a curve must allow for the effect of curvature. Additional sway or lurch due to curve can be considered as fully counteracted by the inward lean of the vehicle due to superelevation.
4. Allowance for curvature: The allowance for curvature for a vehicle 21340mm long, 14785mm between bogie centre shall be calculated as under:-

At the centre of vehicle

$$V = \frac{14.785 \times 14.785 \times 1000}{8R} = \frac{27330}{R} \text{ mm}$$

At the end of vehicle

$$V_o = \frac{21.340 \times 21.340 \times 1000}{8R} - \frac{27330}{R} = \frac{29600}{R} \text{ mm}$$

Where R is the radius of the curve in metres.

5. Allowance for superelevation: The lean due to superelevation at any point at height 'h' above rail level is given by :

$$L = \frac{h}{g} \times S \quad \text{where } S \text{ is the superelevation, } g \text{ is the gauge of the track.}$$

6. Allowance for additional sway on curves: The provision for additional lurch and sway on the inside of a curve as given in the 1913 and 1922 schedules has been adopted, namely one-fourth of the lean due to superelevation. No provision has been made for additional sway due to a curve in the outward direction for reasons already given in paragraph 3 above.
7. Platforms:- For platforms the total additional clearance to be provided is:

On the inside of a curve

$$(i) \quad V + \frac{5}{4} L - 51 \text{ mm}$$

Where L is the lean in millimetres.

On the outside of a curve--

$$(ii) \quad V_o - 25 \text{ mm.}$$

(see paragraph 2 above)

Column 5 of the Appendix has been calculated for a high passenger platform 840mm according to formula (i).

8. Clearance from adjacent structure on the inside of a curve:-- For obtaining the figures given in columns 6 & 7, formula (i) of paragraph 7 above has been used.
9. Clearance from adjacent structures on the outside of a curve: For column 8, formula (ii) of paragraph 7 above has been used.
10. Extra clearance between adjacent tracks: The worst case will be when the end of a bogie carriage on the inner track is opposite the centre of a similar carriage on the outer track. Nothing is allowed for superelevation, it being assumed that both tracks will be inclined the same amount. Though there are cases where a different superelevation is provided on each track, the distance allowed between centres of tracks gives a sufficient margin of safety to permit of this being omitted from consideration. The formula used for column 9 is

$$V + V_o + \frac{2L}{4}$$

and as the height adopted for the value of h in calculating L, is 3355mm, the above therefore reduces to

$$V + V_o + S$$

11. While locating any permanent structures by the side of the track in the case of trunk routes and main lines which have the potential for the increase of speed in future, the need for additional clearances for realignment of curves for higher speed operation should be kept in view. A table showing extra clearances necessary on curves between structures and the adjacent track, and between tracks when there are no structures is given in Annexure -1 for speed of 160 kmph.
12. The clearances worked out (Annexure I) are for a vehicle 21340 mm long with bogie centres 14785 mm apart. For vehicles having different dimensions, the clearances can be worked out in the similar manner.

ADDITIONAL APPENDIX ---- EXTRA CLEARANCES

EXTRA CLEARANCES ON CURVES FOR HIGH SPEED ROUTES (160 KMPH)

| Degree of curvature | Radius of curve | Maximum permissible speed | Super-elevation | Extra Clearance between structure and adjacent track | | | Extra clearance between adjacent track when there is no structure between track | |
|---------------------|-----------------|---------------------------|-----------------|------------------------------------------------------|-----------------------------|-----------------------------|---------------------------------------------------------------------------------|-----------------------------|
| | | | | Inside of curve | | | | Outside of curve any height |
| | | | | Upto 840 mm above rail level | At 4420 mm above rail level | At 5410 mm above rail level | | |
| 1 | 2 | 3 | 4 | 5 | 6 | 7 | 8 | 9 |
| degree | m | kmph | mm | mm | mm | mm | mm | mm |
| 1 | 1750 | 158 | 95 | 25 | 280 | 350 | - | 130 |
| 1.5 | 1167 | 145 | 142 | 60 | 440 | 545 | - | 190 |
| 2 | 875 | 130 | 164 | 85 | 520 | 640 | 10 | 230 |
| 3 | 583 | 106 | 165 | 100 | 540 | 665 | 25 | 265 |
| 4 | 438 | 92 | 165 | 115 | 555 | 680 | 45 | 295 |
| 5 | 350 | 83 | 165 | 130 | 570 | 695 | 60 | 300 |
| 6 | 292 | 75 | 165 | 145 | 590 | 710 | 75 | 360 |
| 7 | 250 | 70 | 165 | 165 | 605 | 725 | 95 | 395 |
| 8 | 219 | 65 | 165 | 180 | 620 | 740 | 110 | 425 |
| 9 | 194 | 62 | 165 | 195 | 635 | 755 | 130 | 460 |
| 10 | 175 | 58 | 165 | 210 | 650 | 770 | 145 | 490 |

Note:

- i) For any other heights extra clearance shall be worked out as per Appendix of this Schedule of Dimension.
- ii) In case of new line/ Gauge conversion/ Doubling (except in platform area)-
 - (a) Below the rail level up to the formation level of the track on straight and curves up to radius of 875m 2575mm
 - (b) Below the rail level up to the formation level of the track on curves with radius less than 875m 2725mm
- iii) Maximum permissible speed has been worked out for cant deficiency value of 100mm and cant of 165mm. However, maximum cant of 185mm may be assumed for the purpose of locating all permanent structure by the side of the curves on new construction and doubling on Group A routes having potential of increasing the speed in future.

APPENDIX A TO CHAPTER V-A

Clearances required for 25 K.V., single phase,

A.C. Electric Traction

1. It is desirable to provide the maximum possible clearances in the case of lines equipped for 25kV AC 50 Cycle single phase electric traction.

Minimum Clearances between live bare conductors/ pantographs and Structure –

- (a) Short term clearances - Vertical and lateral distance between live : 200 mm
Conductors and earth (normally existing only for a brief period)
 - (b) Long term clearance - Vertical and lateral distance between live : 250mm
Conductors and earth (which may remain for a considerable period)
2. In order to ascertain whether the requisite clearance would be available under an existing structure, the permissible height of the contact wire shall be determined. For this purpose, the following particulars should be known:-
 - (a) Particulars of the structure including profile
 - (b) Allowance for slewing of tracks
 - (c) Allowance for low joints in tracks.
 - (d) Radius of curvature of track under the structure
 - (e) Super-elevation of track under the structure
 - (f) Maximum permissible speed under the structure
 - (g) Maximum dimensions of over-dimensional consignments which are permissible and safety measures which would be taken for movement of over-dimensional consignments.
 - (h) Location of the structure in relation to level crossings, water columns and turnouts in the vicinity.
 - (i) Type of overhead equipment.
 3. After determining permissible height of the contact wire based on above particulars, the clearance required between the lowest portion of the bridge or structure and the top most position of the overhead wire shall be determined in each case after study of the following:
 - a) System of tensioning of the overhead equipment
 - b) Atmospheric conditions.
 - c) Maximum permissible number of electric locomotives per train (double or triple headed)
 - d) Location of the structure in relation to points and crossings, overlap, spans, etc.
 - e) Length of structure along tracks.
 - f) Type of structure, girder, masonry etc.
 - g) The span of overhead equipment under the bridge
 - h) Presence of traction feeder

i) Likelihood of diesel locomotives halting under the structure.

4. (a) The minimum height of contact wire for a stock height of 4.42m to be able to run on all sections electrified with 25 kV A.C. traction system with live traction overhead equipment :

| | |
|------------------------------------------------------|---------|
| (i) Height of the locomotive | : 4.42m |
| (ii) Minimum clearances to contact wire | : 0.25m |
| (iii) Allowance for track maintenance | : 0.02m |
| (iv) Minimum height of contact wire (<u>Total</u>) | : 4.69m |

Note: For OHE span length of 49.5m or below, the oscillations of contact wire get reduced to 0.05m and the minimum height of contact wire in para 4(a)(iv) can be reduced to 4.69m.

(b) After determining the minimum height of contact wire on the assumption that it would permit passage of standard locomotives and stock, the maximum height of over Dimensional Consignments(ODC) with the live over head equipment at speed over 15km/h (when vertical oscillation of overhead equipment is pronounced) is derived as under:

| | |
|------------------------------------------------------------------------------------------------|----------------|
| Minimum height of Contact Wire | : 4.69m |
| Less- | |
| (i) Minimum electrical clearance | : 0.20m |
| (ii) Track allowance | : 0.02m |
| (iii) Allowance for vertical oscillation of contact wire under influence of moving pantographs | : 0.05m |
| Total | : 0.27m |

Permissible maximum height of Over Dimensional Consignment : 4.42m.

(c) If an Over Dimensional Consignment is moved at slow speed not exceeding 15 kmph, there will be no downward displacement (due to oscillation) of contact wire. However, to cater for the likelihood of an Over Dimensional Consignment halting under a structure, a clearance of 0.25 m under rest condition is to be provided, vide item 1 of Chapter V - A. In this case the derived height of contact wire may be reduced by 50 mm.

5. In the case of light structures such as foot-over bridges, it would be desirable to keep a standard height of contact wire of 5.50m. In case of heavy structures, such as flyover bridges or road over bridges, it is desirable to keep the height of contact wire as low as possible, consistent with the requirements of movement of Standard Class 'C' Over-Dimensional Consignments of height 4.80m.

ANNEXURE-II

Statement showing the correction slips issued to Indian Railway Schedule of Dimensions (BG), Revised-2004

| Correction Slip No. | File No. | Date of issue | Page Nos. of IRSOD-2004 |
|---------------------|-------------------------------------|---------------|---------------------------------------------|
| 1. | 97/CEDO/SR/14 | March, 2006 | 10 |
| 2. | 97/CEDO/SR/14 | March, 2006 | 10 |
| 3. | CT/SD/REV/BG/MG | Sept, 20 | 3,5,8,9,12,13,14,15,16,19, 21,22,25,31 & 34 |
| 4. | | Not Issued | |
| 5. | CT/SD/REV/BG/MG | Feb, 2009 | 11 |
| 6. | CT/SD/REV/BG/MG | Oct, 2009 | 22 |
| 7. | 2011/CEDO/SD/IRSOD/Elect./02 | March,2012 | 6,7,8,27,28,37,38,39 |
| 8. | 2008/CEDO/SD/09 | Nov, 2012 | 16 |
| 9. | 2012/CEDO/SD/IRSOD/O | Oct, 2012 | 4,8 and10 |
| 10. | 2011/CEDO/SD/IRSOD/Elect./02 | Nov, 2012 | 6,7,8,14,27,28, 32 and 38 |
| 11. | 2012/CEDO/SD/IRSOD/O/01 | Dec, 2012 | 12 |
| 12. | 2013/CEDO/SD/IRSOD/O/01 | May, 2013 | 10 |
| 13. | 2011/CEDO/SD/IRSOD/Elect./02 | Oct, 2013 | 6,7,8,14 and 32 |
| 14. | 2012/CEDO/SD/IRSOD/O/03 | Nov, 2013 | 19,20,21,23,25 |
| 15. | 2011/CEDO/SD/IRSOD/Elect./02 | June,2014 | 14 |
| 16. | 2015/CEDO/SD/IRSOD/O/01 | May.,2015 | 10 and 14 |
| 17. | 2015/CEDO/SD/IRSOD/O/01 | Aug, 2015 | 10 |
| 18. | 2012/CEDO/SD/IRSOD/O | Nov, 2016 | 4 |
| 19. | 2012/CEDO/SD/IRSOD/O(Pt.) | Nov.,2016 | 10 |
| 20. | 2011/CEDO/SD/IRSOD/Elect./02(Pt.II) | July, 2017 | 7 and 8 |
| 21. | 2012/CEDO/SD/IRSOD/O/ACS-21 | Sept, 2017 | 28 |
| 22. | 2011/CEDO/SD/IRSOD/O/1 | Dec, 2017 | 6, 7, 14, 12 |

| | | | |
|-----|-----------------------------------------------|------------|-----------------------|
| 23. | 2011/CEDO/SD/IRSOD/O/2 | Dec, 2017 | 12 |
| 24. | 2017/CEDO/SD/IRSOD/O/2 | Aug, 2018 | 12 |
| 25. | 2018/CEDO/SD/IRSOD/ACS | Nov, 2018 | 04 |
| 26. | 2017/CEDO/SD/IRSOD/O/ACS-83 rd TSC | Jan, 2019 | 4,6,9,10, 14,20,22,25 |
| 27. | 2019/CEDO/SD/IRSOD/O/ACS-27 | July, 2019 | 4, 10, 12,21,25,28 |
| 28. | 2019/CEDO/SD/IRSOD/ O/ACS-27 | July, 2019 | 10 |
| 29. | 2019/CEDO/SD/IRSOD/ O/ACS-27 | May, 2020 | 10 |
| 30. | 2020/CEDO/SD/IRSOD/ O/ACS-30 | Feb, 2021 | 4, 6, 10,14 |
| 31. | 2021/CEDO/SD/IRSOD/ O/ACS-a | Oct, 2021 | 30, 31, 32 |
| 32. | 2021/CEDO/SD/IRSOD/ O/ACS_b | Oct, 2021 | 10 |

STANDARD DIMENSIONS FOR TUNNELS & THROUGH GIRDER BRIDGES
SCHEDULE I - CHAPTER I

DIAGRAM No. 1A
1676mm GAUGE

- NOTE:-**
1. WHERE THE LINE IS ON A CURVE ,THE HORIZONTAL DISTANCE OF ANY STRUCTURE FROM THE CENTRE OF ADJACENT TRACK AND THE DISTANCE BETWEEN CENTRES OF TRACKS ARE TO BE INCREASED ACCORDING TO THE APPENDIX.
 2. WHEN RE-SPACING EXISTING LINES,THE MINIMUM DISTANCE CENTRE TO CENTRE OF TRACKS MAY BE REDUCED FROM 4725 TO NOT LESS THAN 4495 FOR THE PURPOSE OF AVOIDING HEAVY ALTERATIONS TO TUNNELS OR THROUGH GIRDER BRIDGES. THE 4725 DIMENSION IS TO BE ADOPTED FOR ALL NEW WORKS.

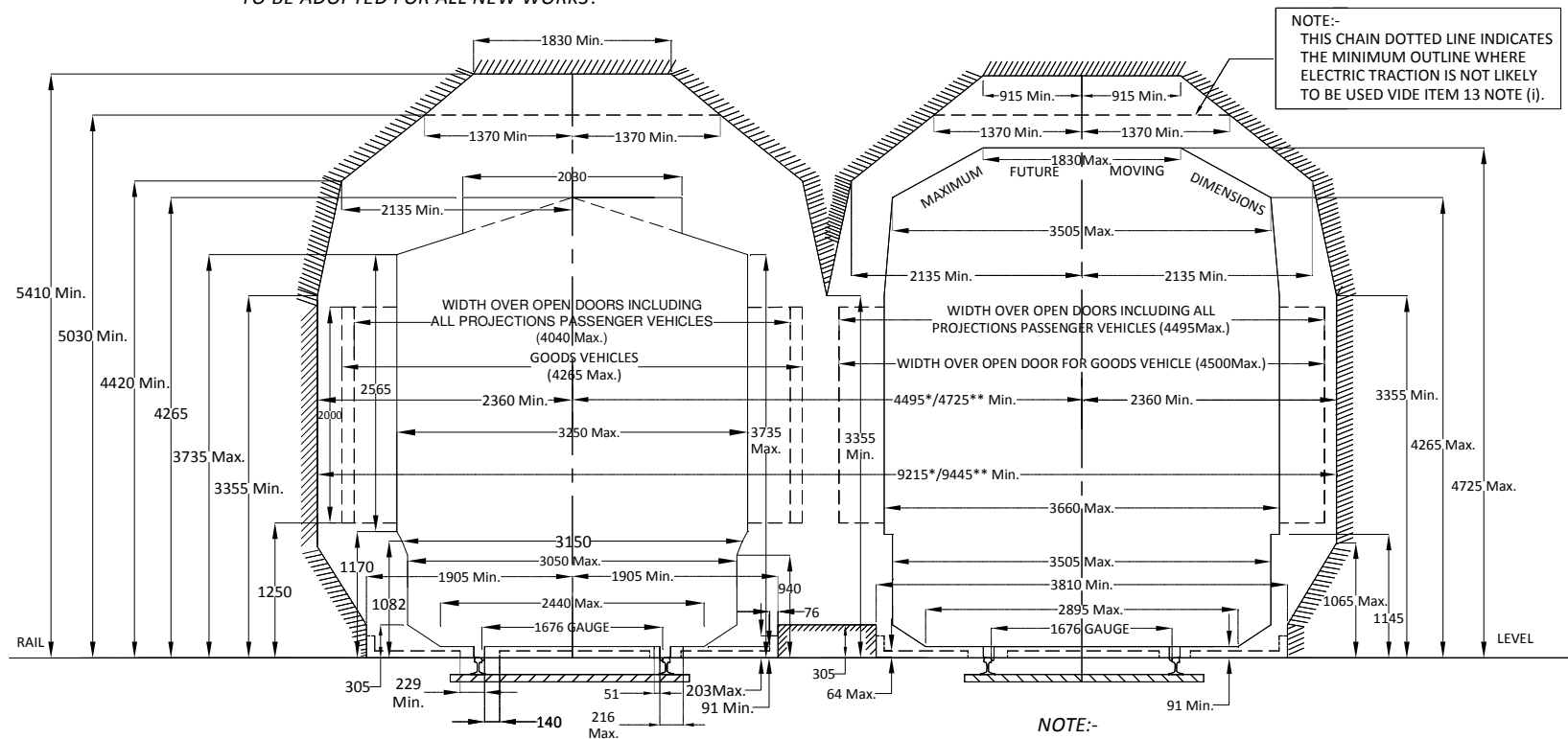

NOTE:- ALL DIMENSIONS ARE IN MILLIMETRES EXCEPT WHERE OTHERWISE SHOWN.

- NOTE:-**
- * - For existing works
 - ** - For new works or alteration to existing works

DIAGRAM No. 1A (MODIFIED)
1676 mm GAUGE

STANDARD DIMENSIONS FOR TUNNELS & THROUGH GIRDER BRIDGES
TO SUIT 25 k.V. A.C. TRACTION SCHEDULE I CHAPTER I

NOTE:- THE DISTANCES SPECIFIED APPLY ONLY IN CASE OF STRAIGHT TRACKS. ON CURVES, THE HORIZONTAL DISTANCE SHOULD BE INCREASED BY AN AMOUNT 'D' TO ALLOW FOR THE LEAN DUE TO SUPER-ELEVATION CALCULATED BY THE FOLLOWING FORMULA, WHERE 'H' IS THE HEIGHT OF THE CONTACT WIRE, 'S' THE SUPER-ELEVATION AND 'G' THE GAUGE OF THE TRACK, ALL DIMENSIONS BEING IN METRES $D=HxS/G$

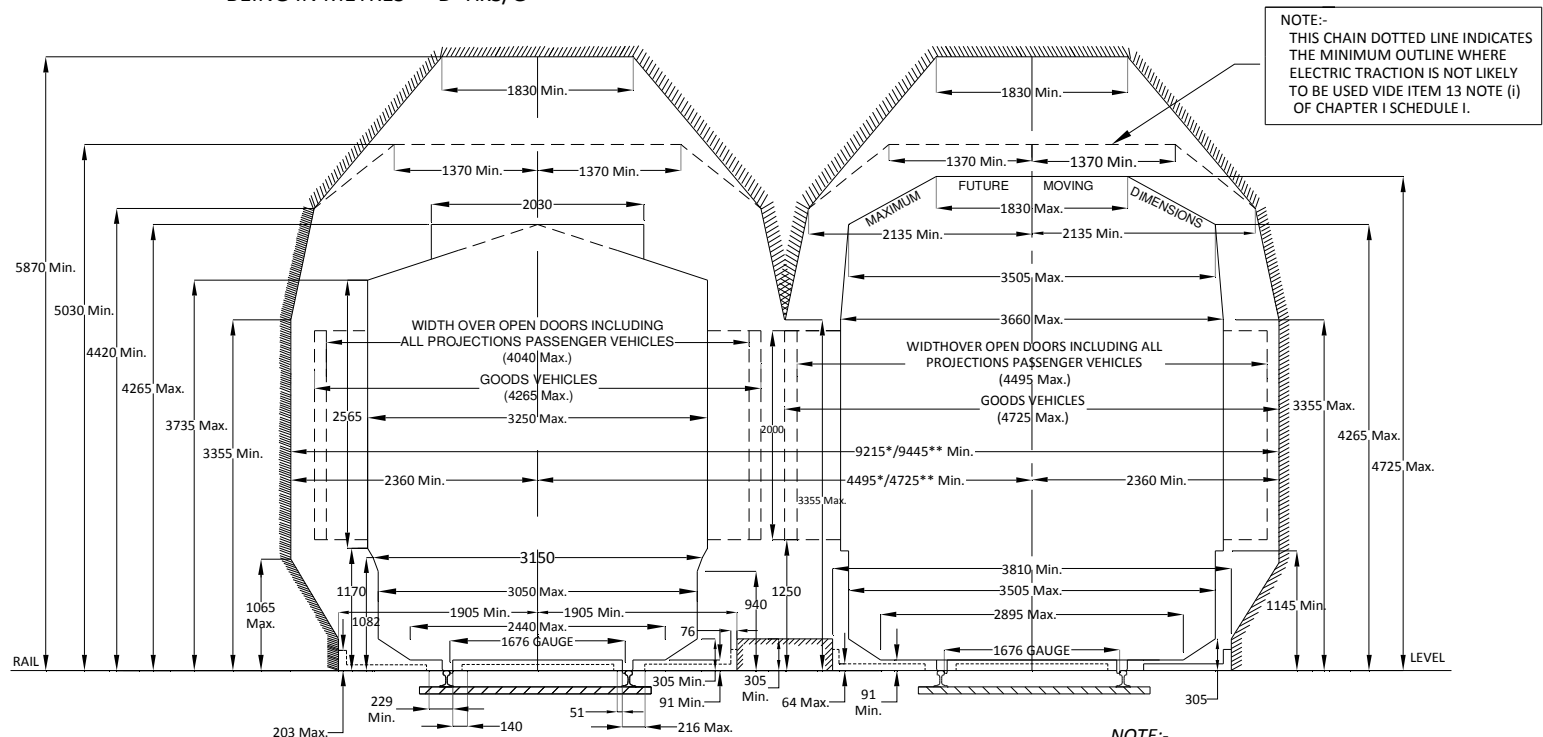

NOTE:- THIS CHAIN DOTTED LINE INDICATES THE MINIMUM OUTLINE WHERE ELECTRIC TRACTION IS NOT LIKELY TO BE USED VIDE ITEM 13 NOTE (i) OF CHAPTER I SCHEDULE I.

NOTE:- ALL DIMENSIONS ARE IN MILLIMETRES EXCEPT WHERE OTHERWISE SHOWN.

NOTE:-
 * - For existing works
 ** - For new works or alteration to existing works

STANDARD DIMENSIONS OUT OF STATIONS SCHEDULE I - CHAPTER I

DIAGRAM No. 1B 1676 mm GAUGE

NOTE:- WHERE THE LINE IS ON A CURVE, THE HORIZONTAL DISTANCE OF ANY STRUCTURE FROM THE CENTRE OF ADJACENT TRACK AND THE DISTANCE BETWEEN CENTRES OF TRACKS ARE TO BE INCREASED ACCORDING TO THE APPENDIX.

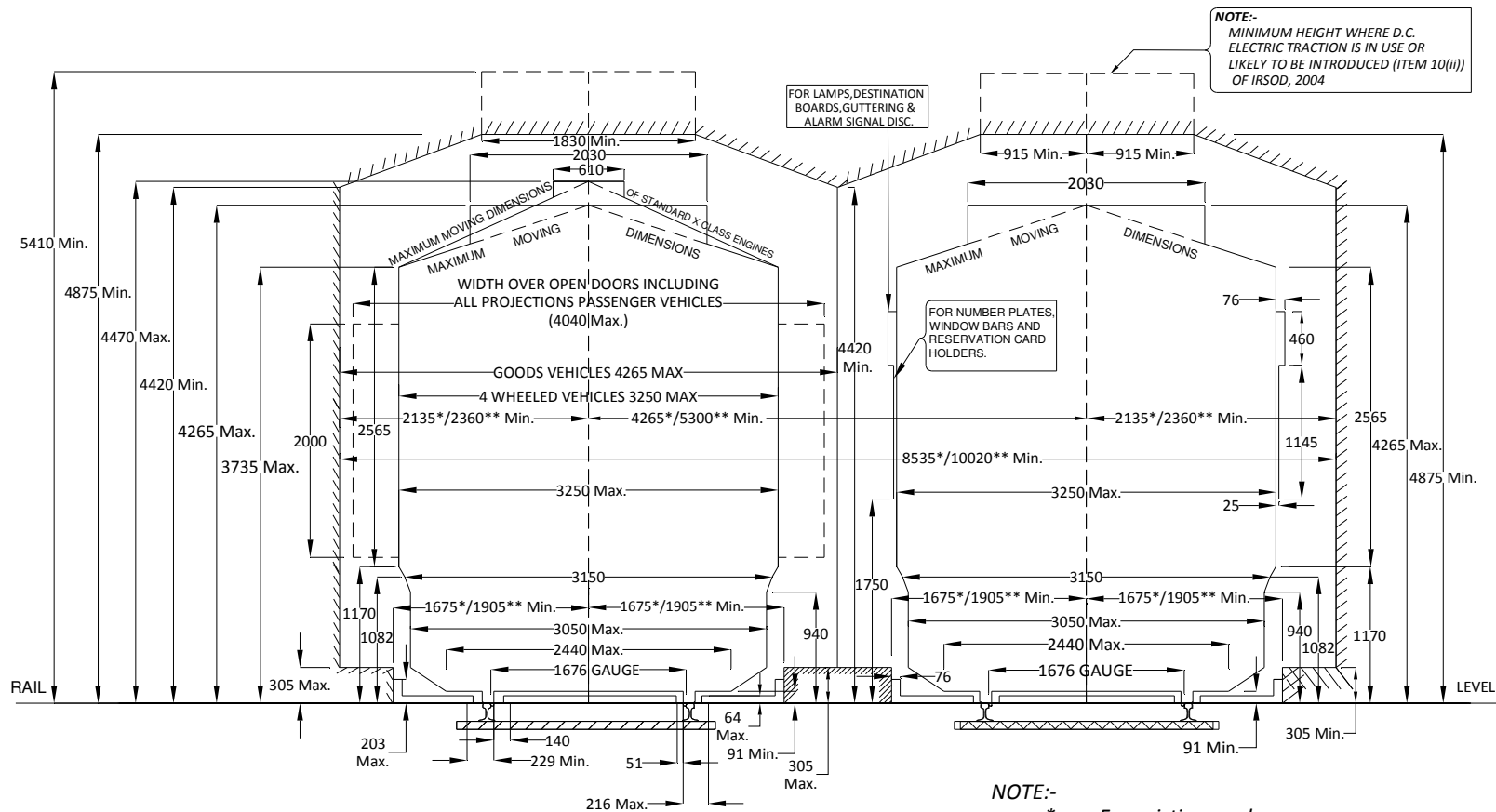

NOTE:- MINIMUM HEIGHT WHERE D.C. ELECTRIC TRACTION IS IN USE OR LIKELY TO BE INTRODUCED (ITEM 10(iii)) OF IRSOD, 2004

FOR LAMPS, DESTINATION BOARDS, GUTTERING & ALARM SIGNAL DISC.

FOR NUMBER PLATES, WINDOW BARS AND RESERVATION CARD HOLDERS.

NOTE:- ALL DIMENSIONS ARE IN MILLIMETRES EXCEPT WHERE OTHERWISE SHOWN.

NOTE:-
* - For existing works
** - For new works or alteration to existing works

STANDARD DIMENSIONS OUT OF STATIONS

TO SUIT 25 KV. A.C. TRACTION

SCHEDULE I - CHAPTER I

DIAGRAM No. 1C
1676 mm GAUGE

NOTE:- THE DISTANCES SPECIFIED, APPLY ONLY IN CASE OF STRAIGHT TRACK. ON CURVES, THE HORIZONTAL DISTANCE SHOULD BE INCREASED BY AN AMOUNT 'D' TO ALLOW FOR THE LEAN DUE TO SUPER-ELEVATION CALCULATED BY THE FOLLOWING FORMULA, WHERE 'H' IS THE HEIGHT OF THE CONTACT WIRE, 'S' THE SUPERELEVATION AND 'G' THE GAUGE OF THE TRACK, ALL DIMENSIONS BEING IN METRES $D = \frac{H \times S}{G}$

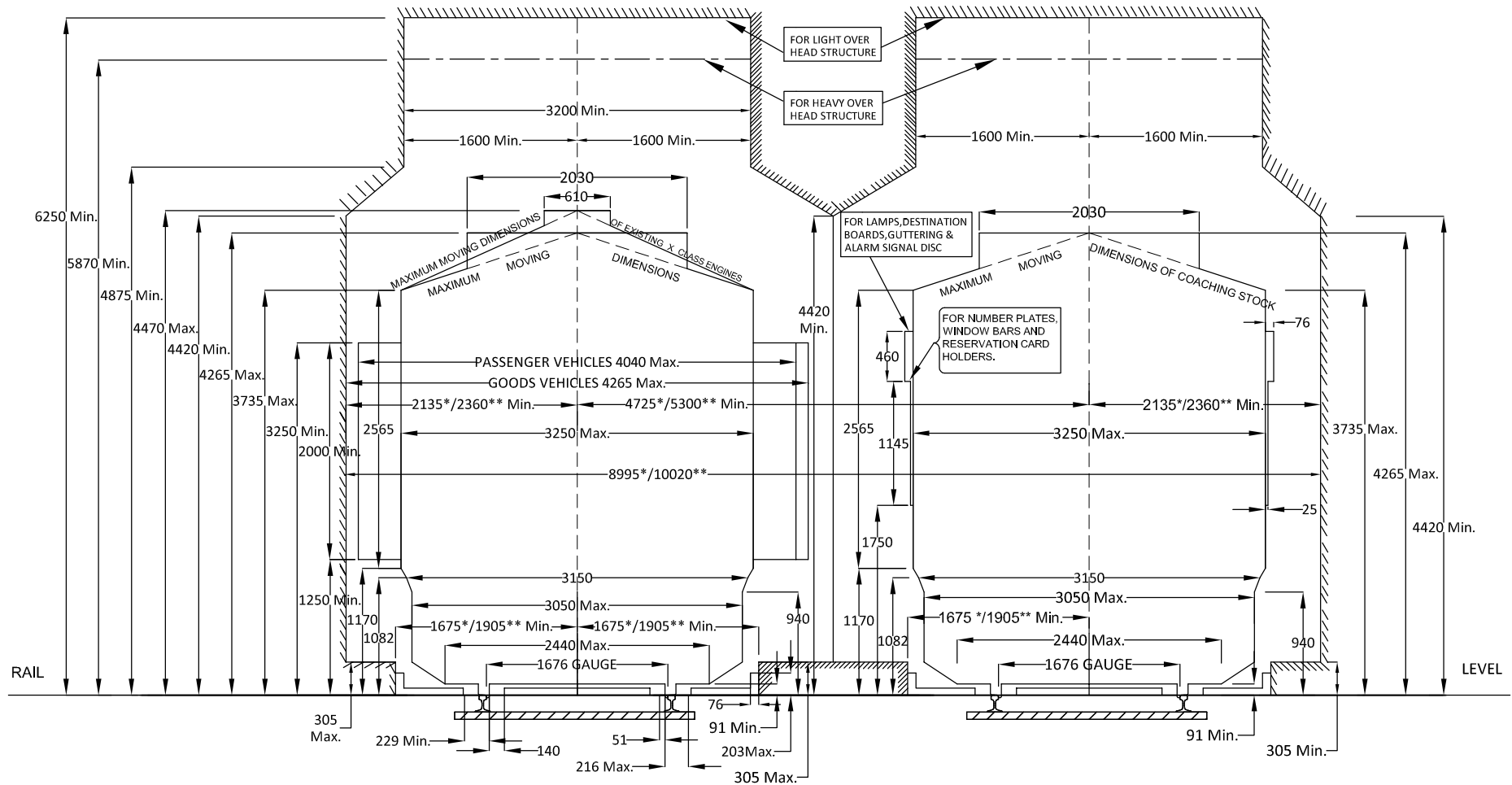

NOTE:- ALL DIMENSIONS ARE IN MILLIMETRES EXCEPT WHERE OTHERWISE SHOWN.

NOTE:-

* - For existing works

** - For new works or alteration to existing works

MAXIMUM MOVING DIMENSIONS

DIAGRAM No. 1D
(EDO/T-2202)
1676mm GAUGE

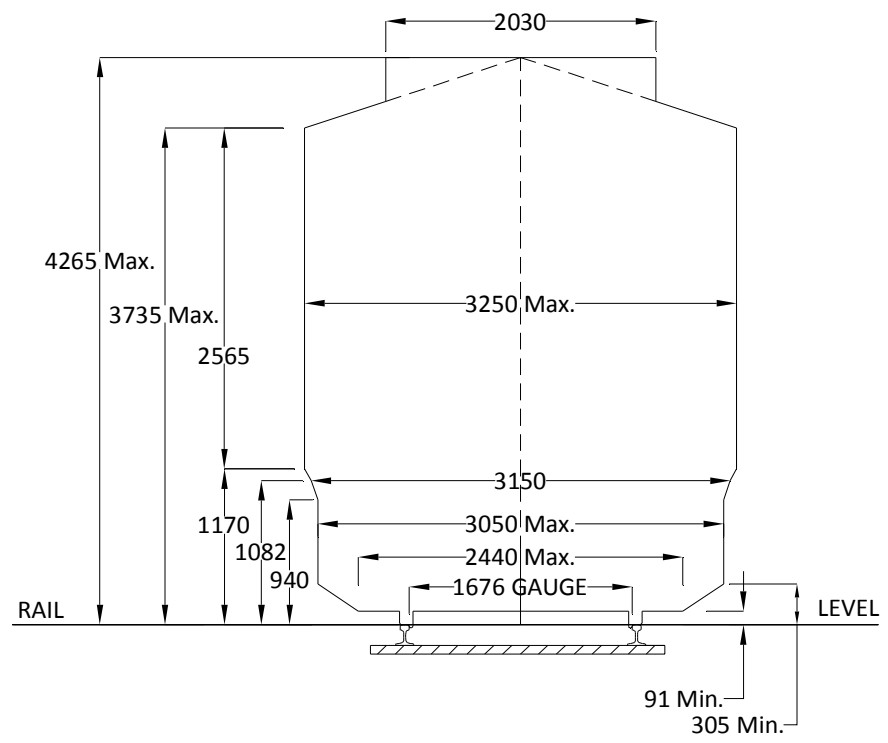

NOTE:- ALL DIMENSIONS ARE IN MILLIMETRES EXCEPT WHERE OTHERWISE SHOWN.

DIAGRAM NO. 2
1676 mm GAUGE

STANDARD DIMENSIONS IN STATIONS
TO SUIT 25 kV.A.C. TRACTION SCHEDULE I-CHAPTER II

NOTE:- THE DISTANCES SPECIFIED, APPLY ONLY IN CASE OF STRAIGHT TRACK. ON CURVES, THE HORIZONTAL DISTANCE SHOULD BE INCREASED BY AN AMOUNT 'D' TO ALLOW FOR THE LEAN DUE TO SUPER-ELEVATION CALCULATED BY THE FOLLOWING FORMULA, WHERE 'H' IS THE HEIGHT OF THE CONTACT WIRE, 'S' THE SUPERELEVATION AND 'G' THE GAUG OF THE TRACK, ALL DIMENSIONS BEING IN METRES $D = \frac{H \times S}{G}$

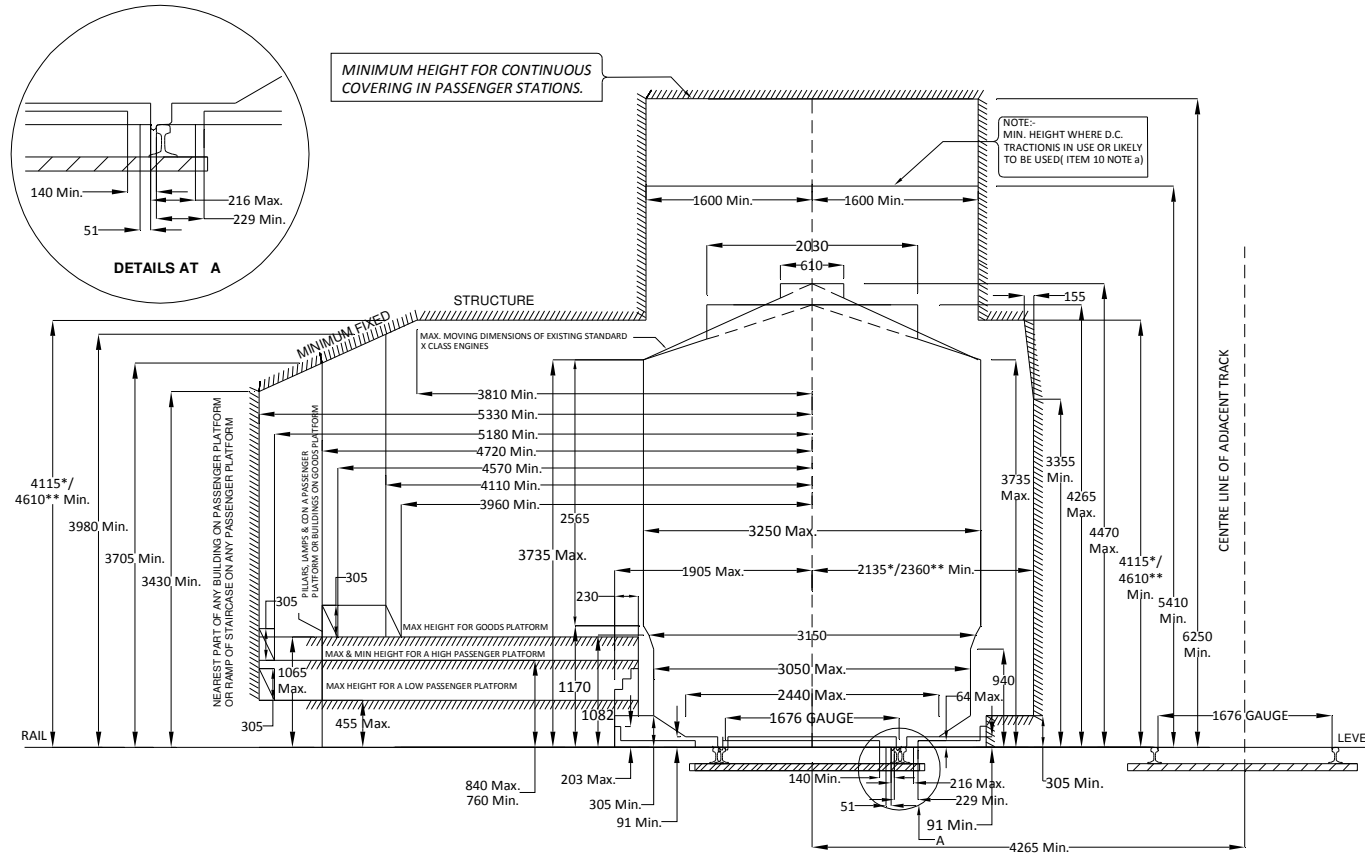

NOTE:- ALL DIMENSIONS ARE IN MILLIMETRES EXCEPT WHERE OTHERWISE SHOWN.

NOTE:-
* - For existing works
** - For new works or alteration to existing works

DIGRAM NO. 3 (FIG I) 1676mm GAUGE

INFRINGEMENTS OF SCHEDULE - I

FOR 3660 mm GOODS STOCK & NEW
STANDARD LOCOMOTIVES IN EXISTING
BRIDGES ONLY

PERMITTED UNDER SCHEDULE-II
MINIMUM CLEARANCES ON EXISTING GIRDER BRIDGES

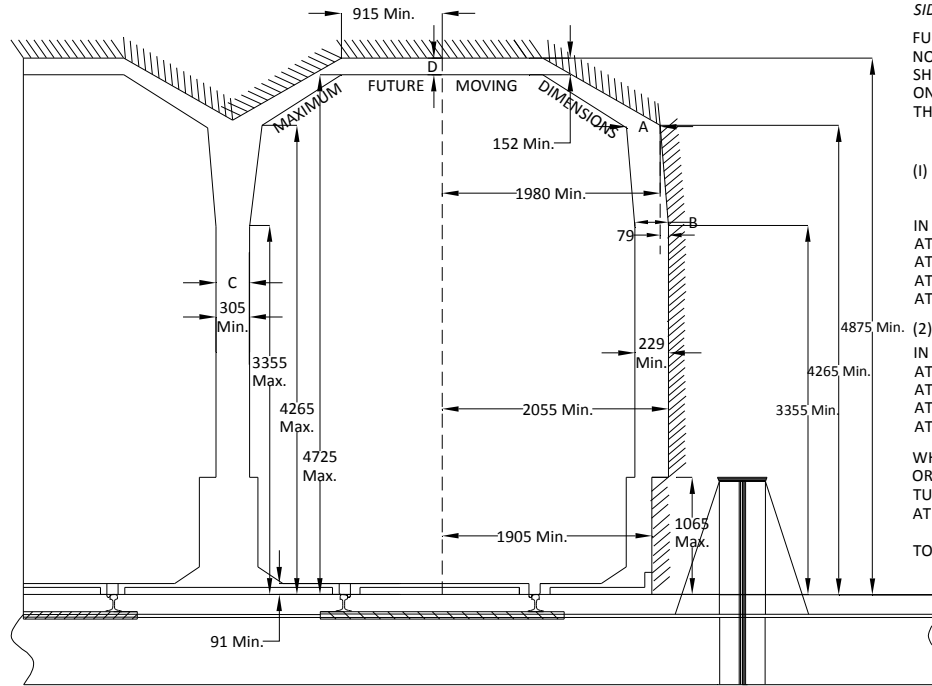

NOTES:-

FULL LINES SHOW MAXIMUM MOVING DIMENSIONS OF FUTURE 3660 WIDE STOCK & OF EXISTING 3200/3250 WIDE STOCK & OUTLINE OF EXISTING 3660 WIDE ELECTRIFIED STOCK DOTTED LINES SHOW OUTLINE OF NEW STANDARD X.E. & W.H. ENGINES & OF PROPOSED 3660 WIDE HIGH SIDED OPEN TRUCK.

FULL HATCHED LINES SHOW DIMENSIONS WHICH SHOULD NOT BE INFRINGED IN TUNNELS, DOTTED HATCHED LINES SHOW DIMENSIONS WHICH SHOULD NOT BE INFRINGED ON GIRDER BRIDGES WHERE THE TRACK IS FIXED TO THE GIRDERS.

THE MINIMUM PERMISSIBLE CLEARANCES WILL BE.

(I) UNDER ANY CIRCUMSTANCES & SUBJECT TO ANY RESTRICTION OF SPEED WHICH IT MAY BE CONSIDERED NECESSARY TO IMPOSE.

IN TUNNELS
AT A-----229mm
AT B-----305mm
AT C-----380mm
AT D-----229mm

ON GIRDER BRIDGES
AT A----229mm (AT TOP OF SIDES OF VEHICLES)
AT B----229mm (AT SIDES OF VEHICLES)
AT C----305mm (BETWEEN MOVING TRAINS)
AT D----152mm (ABOVE VEHICLES)

(2) FOR UNRESTRICTED SPEED:

IN TUNNELS
AT A-----380mm
AT B-----535mm
AT C-----610mm
AT D-----305mm

ON GIRDER BRIDGES
AT A----229mm (AT TOP OF SIDES OF VEHICLES)
AT B----455mm (AT SIDES OF VEHICLES)
AT C----535mm (BETWEEN MOVING TRAINS)
AT D----229mm (ABOVE VEHICLES)

WHERE DOORS OPENING INWARDS OR OF THE RECESSED OR SLIDING TYPE ARE PROVIDED, THE MINIMUM CLEARANCE IN TUNNELS & BRIDGES MAY BE REDUCED TO 380 AT B & 455 AT C FOR UNRESTRICTED SPEED.

TO THE ABOVE MUST BE ADDED THE EXTRA ALLOWANCES FOR CURVES (SEE APPENDIX.)

NOTE:- ALL DIMENSIONS ARE IN MILLIMETRES EXCEPT WHERE OTHERWISE SHOWN.

INFRINGEMENTS OF SCHEDULE - I
FOR 3660 mm GOODS STOCK & NEW
STANDARD LOCOMOTIVES IN EXISTING
TUNNELS ONLY
PERMITTED UNDER SCHEDULE-II
TUNNEL SECTION OF 1913

DIGRAM NO. 3 (FIG II)
1676mm GAUGE

NOTE:-
 PLEASE REFER TO NOTES GIVEN IN
 DIAGRAM No. 3 (FIG I)

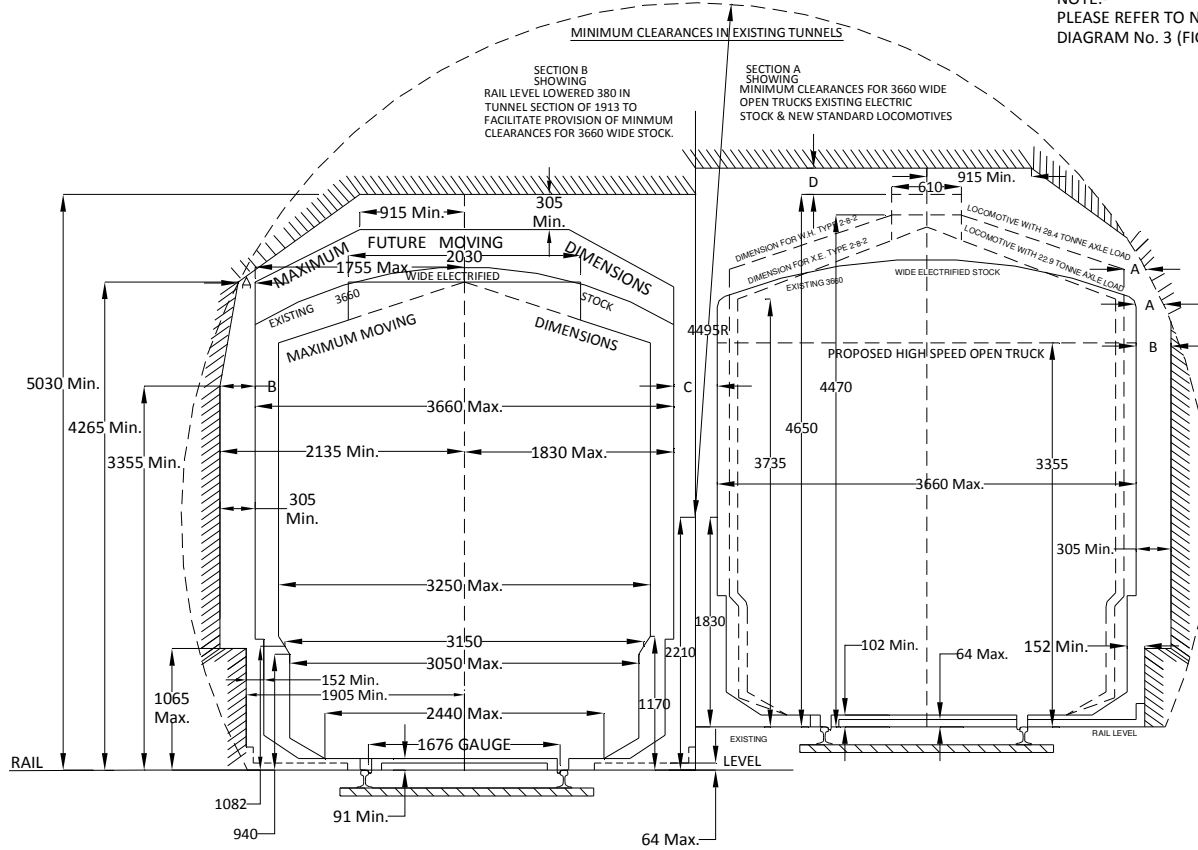

NOTE:- ALL DIMENSIONS ARE IN MILLIMETRES EXCEPT WHERE OTHERWISE SHOWN.

DIAGRAM NO. 4
1676mm GAUGE

MAXIMUM MOVING DIMENSIONS OF 1929 PROFILE

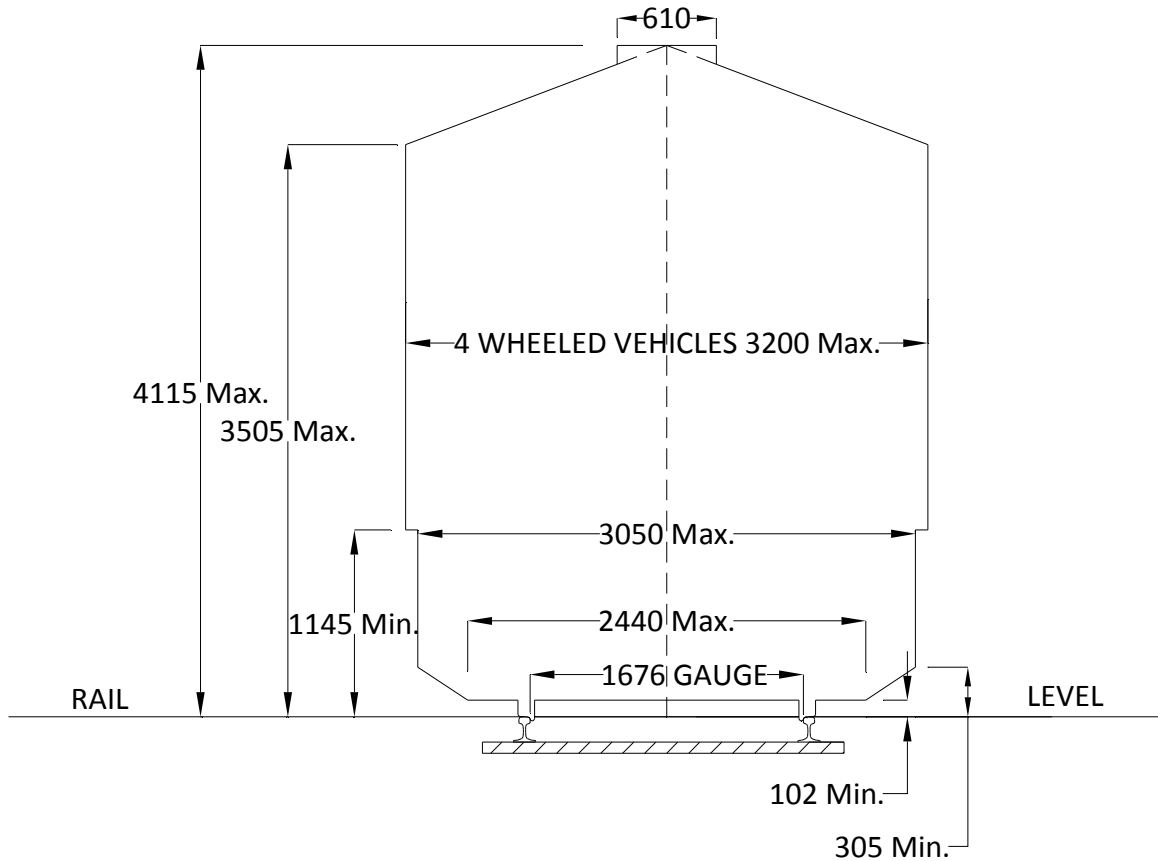

NOTE:- ALL DIMENSIONS ARE IN MILLIMETRES EXCEPT WHERE OTHERWISE SHOWN.